



# Rettungsdatenblätter

## 3

- 350Z Coupé Z33 2002-2009
- 350Z Cabriolet Z33 2003-2009
- 370Z Coupé Z34 2009-
- 370Z Cabriolet Z34 2009-

## A

- ALMERA 3-Türer N16 1995-2007
- ALMERA 4-Türer N16 1995-2007
- ALMERA 5-Türer N16 1995-2007
- ALMERA TINO V10 2000-2006

## C

- CUBE Z12 2010-2011

## E

- e-NV200 ME0M 2014-
- EVALIA M20M 2011-

## G

- GT-R R35 2008-

## I

- INTERSTAR X70 2004-2010

## J

- JUKE F15 2010-

## L

- LEAF ZE0 2011-2013
- LEAF ZE0 2013-

## M

- MICRA 3-Türer K11 1996-2003
- MICRA 5-Türer K11 1996-2003
- MICRA 3-Türer K12 2003-2010
- MICRA 5-Türer K12 2003-2010
- MICRA C+C K12 2005-2009
- MICRA 5-Türer K13 2010-
- MURANO Z50 2005-2008
- MURANO Z51 2008-

## N

- NAVARA King Cab D40 2005-
- NAVARA Crew Cab D40 2005-
- NOTE E11 2006-2013
- NOTE E12 2013-
- NP300 Single Cab D22 2008-2011
- NP300 King Cab D22 2008-2011
- NP300 Crew Cab D22 2008-2011
- NT400 CABSTAR F24 2006-
- NV200 M20 2009-
- NV400 M9 2011-

## P

- PATHFINDER R51 2005-
- PATROL 3-Türer Y61 2000-2009
- PATROL 5-Türer Y61 2000-2009
- PIXO UA0 2009-2013
- PRIMASTAR X83 2003-
- PRIMERA 4-Türer P11 1994-2002
- PRIMERA 5-Türer P11 1994-2002
- PRIMERA Kombi P11 1994-2002
- PRIMERA 4-Türer P12 2002-2008
- PRIMERA 5-Türer P12 2002-2008
- PRIMERA Kombi P12 2002-2008
- PULSAR C13 2014-

## Q

- QASHQAI J10 2007-2014
- QASHQAI+2 J10 2008-2014
- QASHQAI J11 2014-

## T

- TIIDA C11 2006-2011

## X

- X-TRAIL T30 2001-2007
- X-TRAIL T31 2007-2014
- X-TRAIL T32 2014-







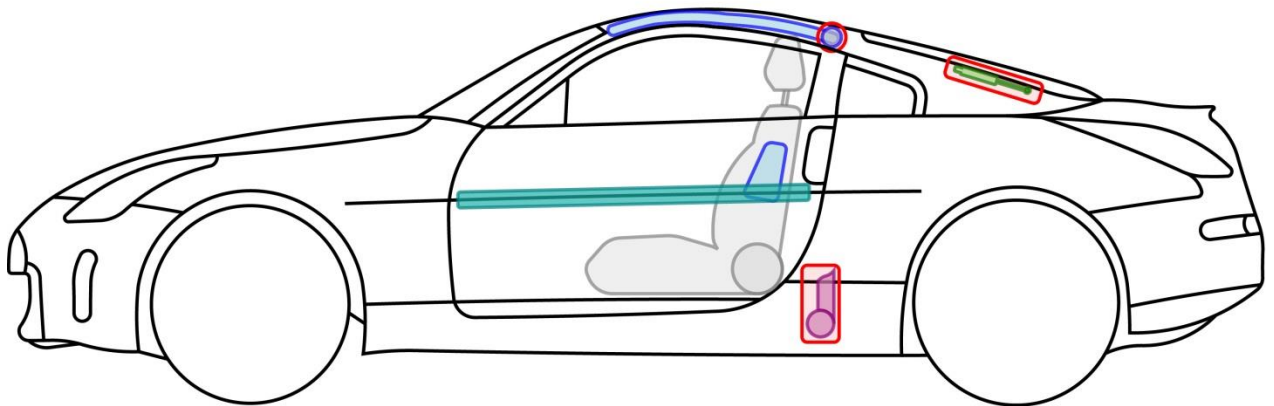
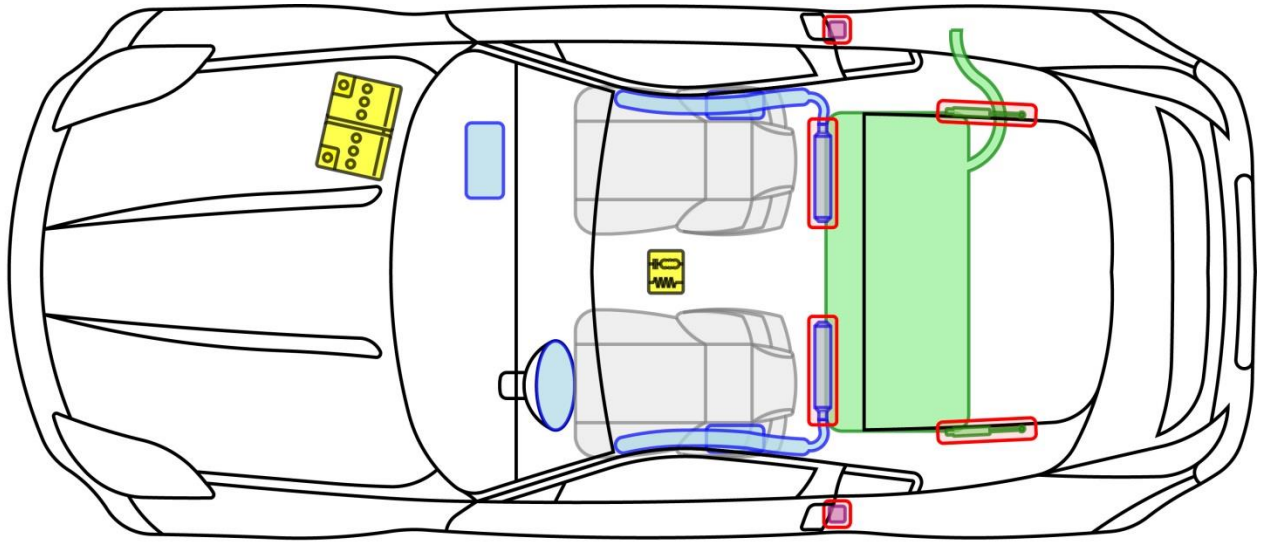

# 350Z Coupé

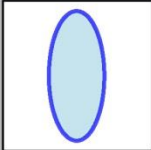
Typ: Z33, 2002-2009

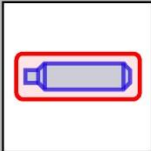

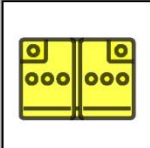
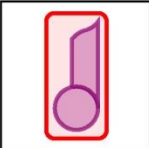
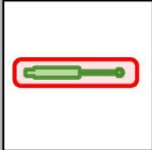
## Legende

	Airbag		Karosserie- verstärkung		Steuergerät
	Gas- generator		Überroll- schutz		Batterie
	Gurt- straffer		Gasdruck- dämpfer		Kraftstoff- tank

350Z







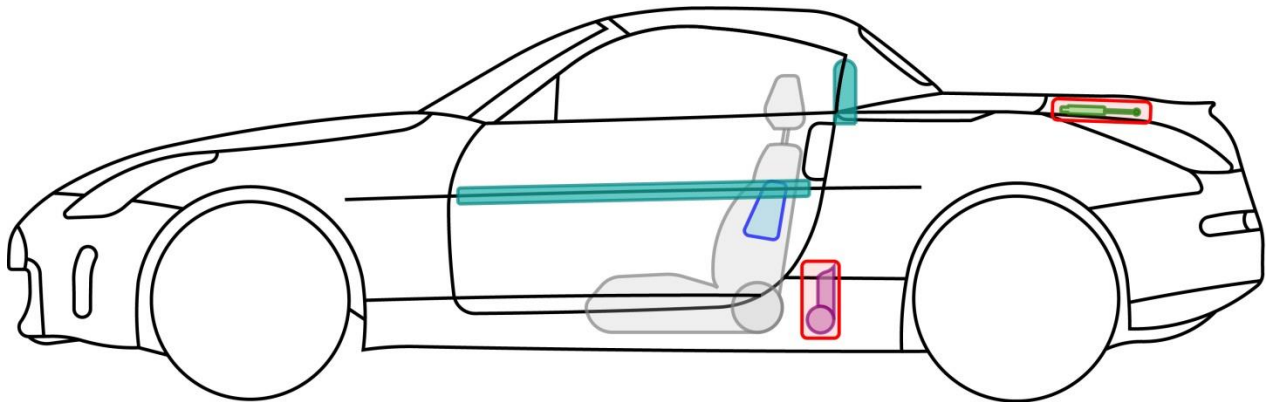
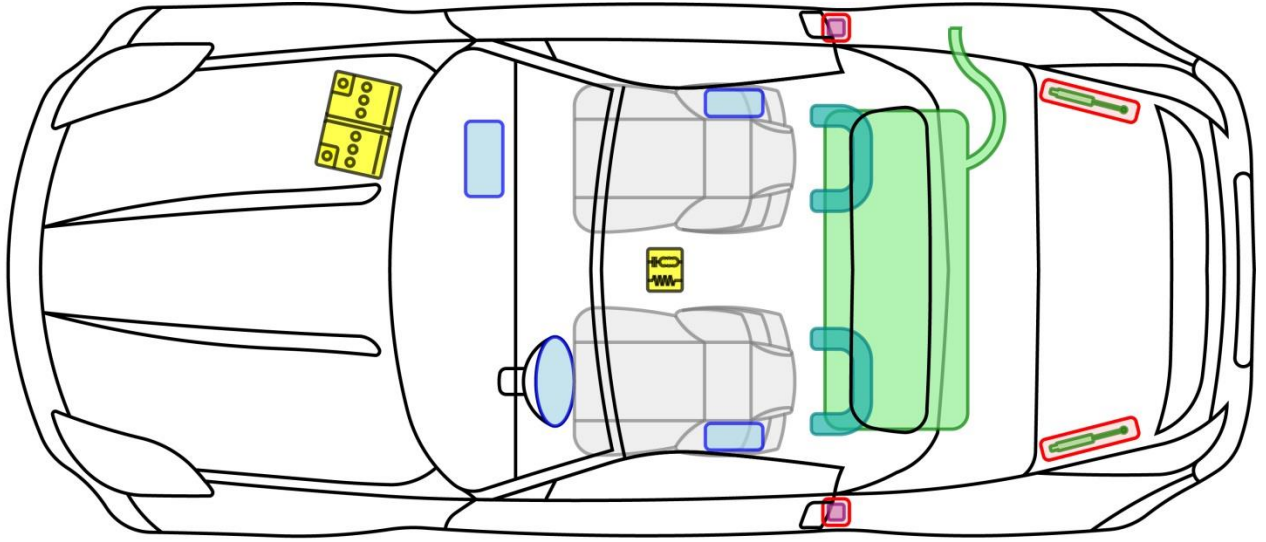

# 350Z Cabriolet

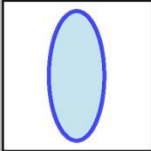
Typ: Z33, 2003-2009

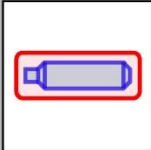

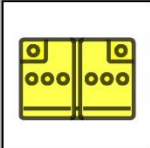
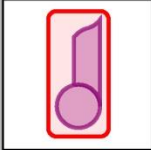
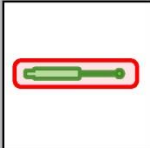
## Legende

	Airbag		Karosserie- verstärkung		Steuergerät
	Gas- generator		Überroll- schutz		Batterie
	Gurt- straffer		Gasdruck- dämpfer		Kraftstoff- tank

350Z







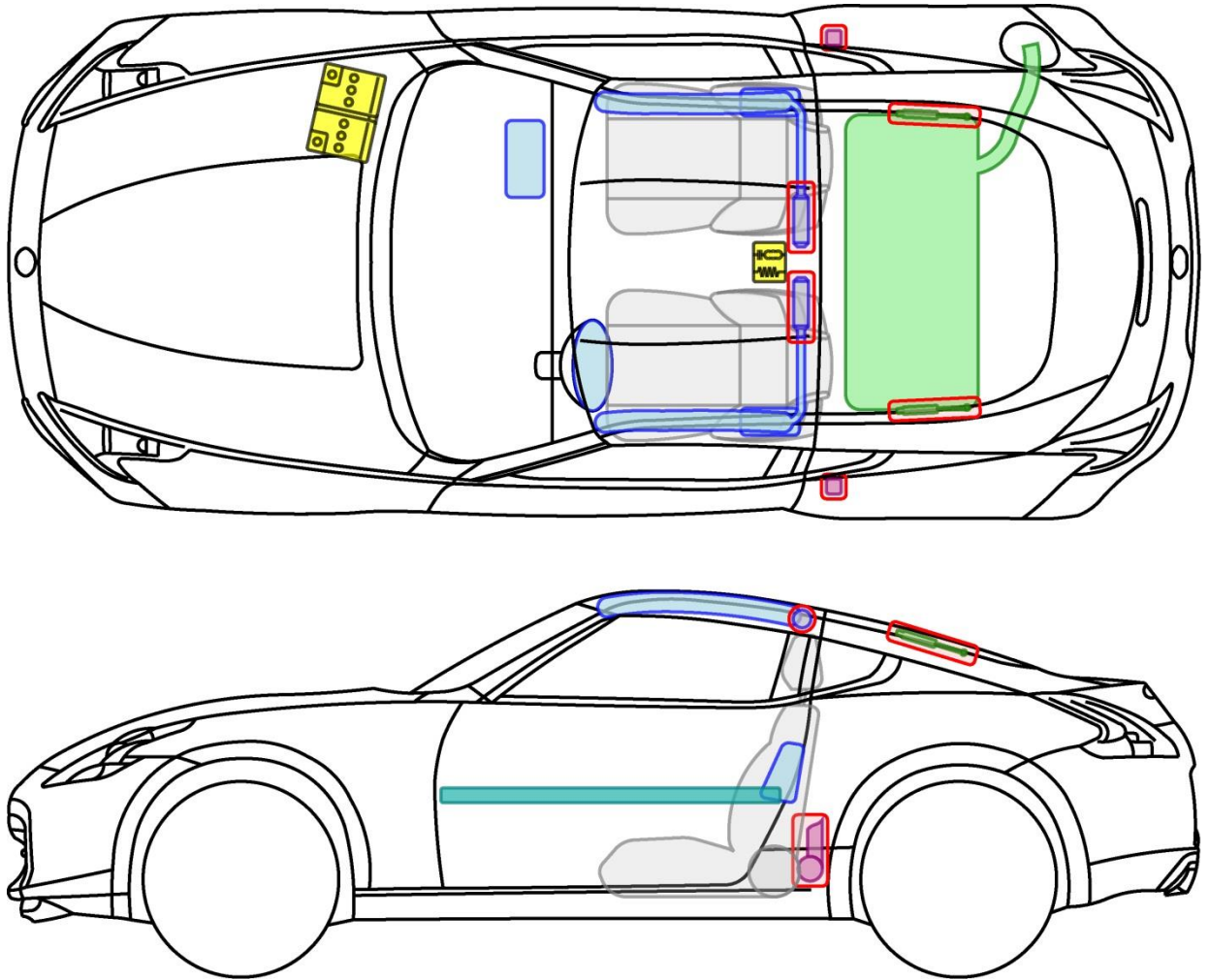

# 370Z Coupé

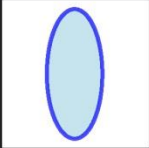
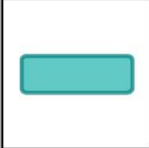
Typ: Z34, 2009-

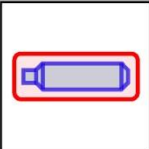

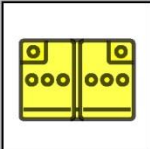
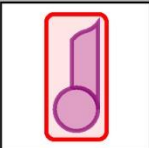
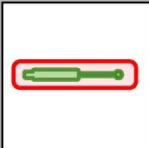
## Legende

	Airbag		Karosserie- verstärkung		Steuergerät
	Gas- generator		Überroll- schutz		Batterie
	Gurt- straffer		Gasdruck- dämpfer		Kraftstoff- tank

370Z









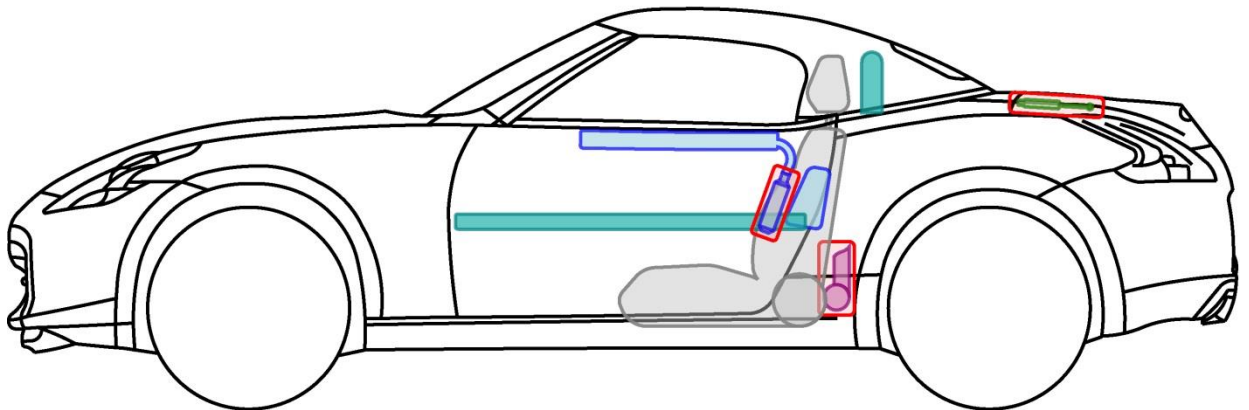
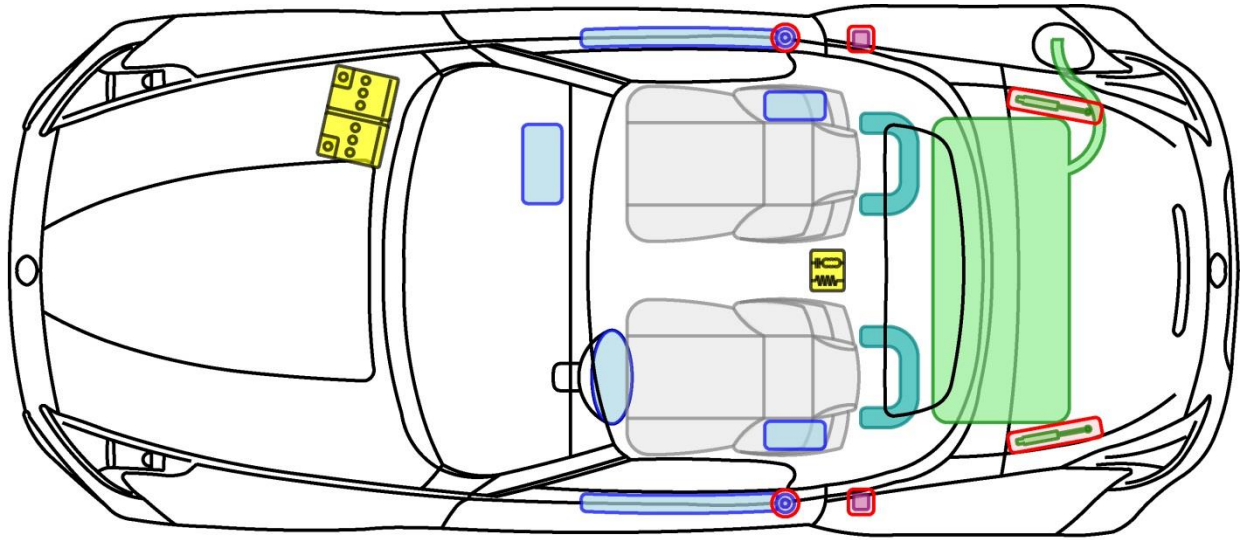

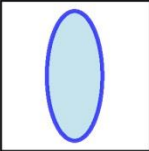
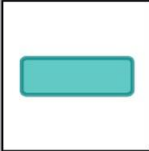

# 370Z Cabriolet

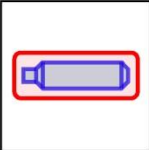
Typ: Z34, 2010-

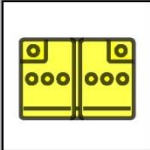

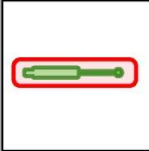
## Legende

	Airbag		Karosserie- verstärkung		Steuergerät
	Gas- generator		Überroll- schutz		Batterie
	Gurt- straffer		Gasdruck- dämpfer		Kraftstoff- tank

370Z



# ALMERA 3-Türer

Typ: N16, 1995-2007

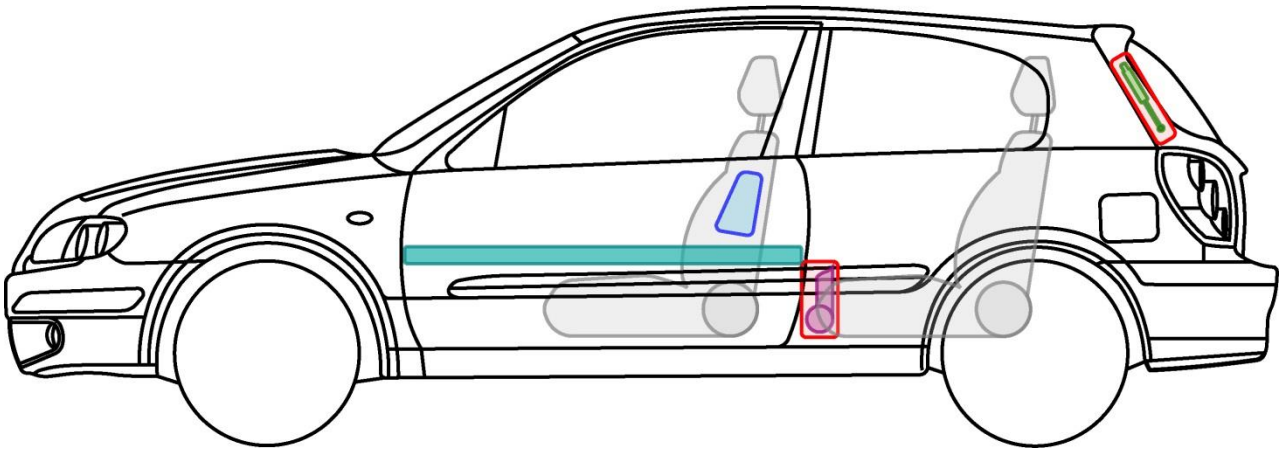
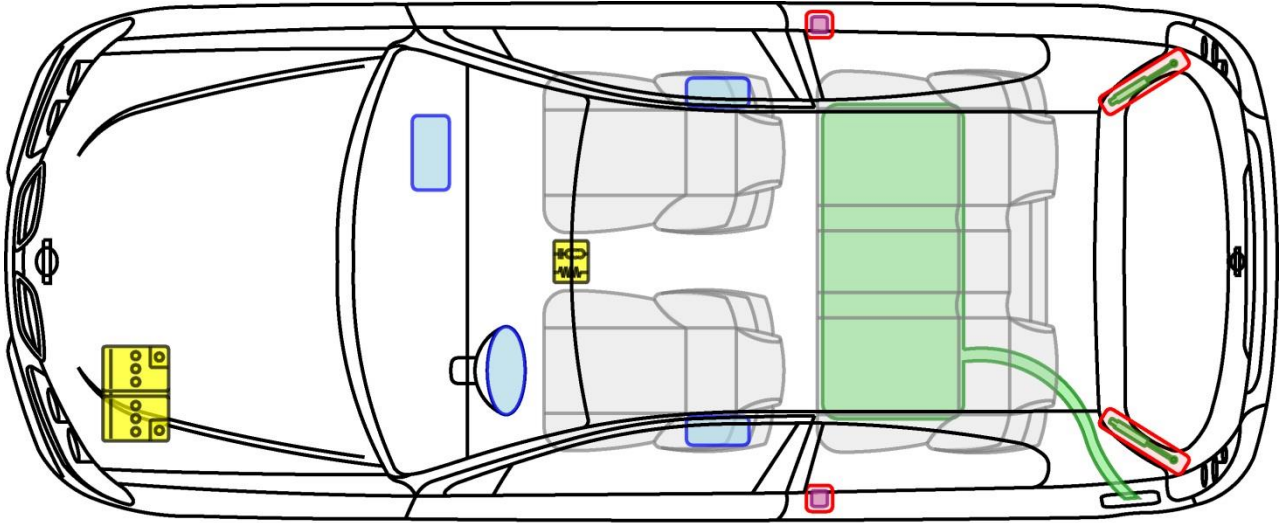

## Legende

	Airbag		Karosserie- verstärkung		Steuergerät
	Gas- generator		Überroll- schutz		Batterie
	Gurt- straffer		Gasdruck- dämpfer		Kraftstoff- tank

ALMERA







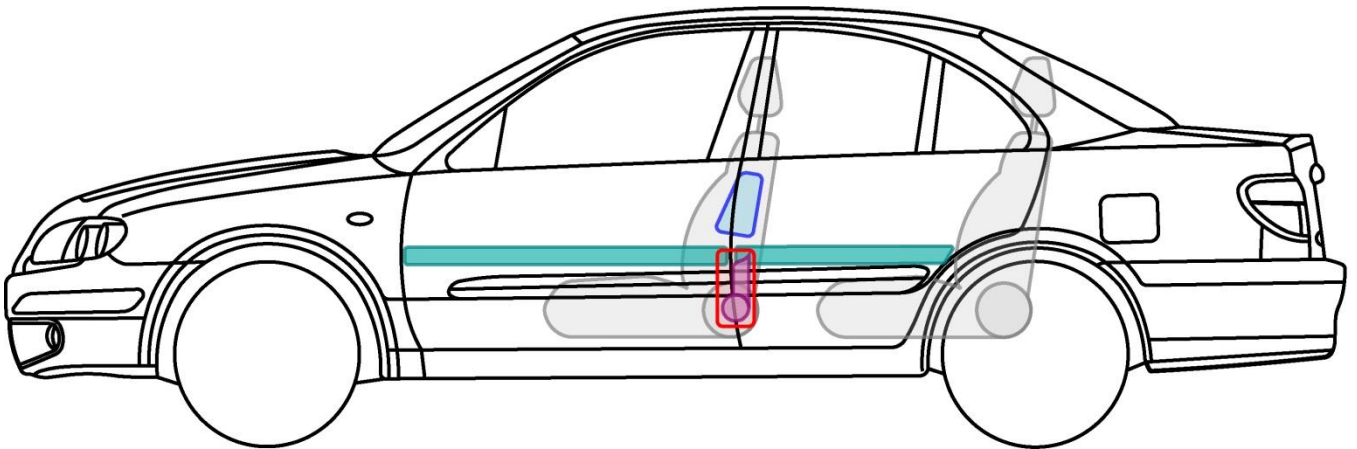
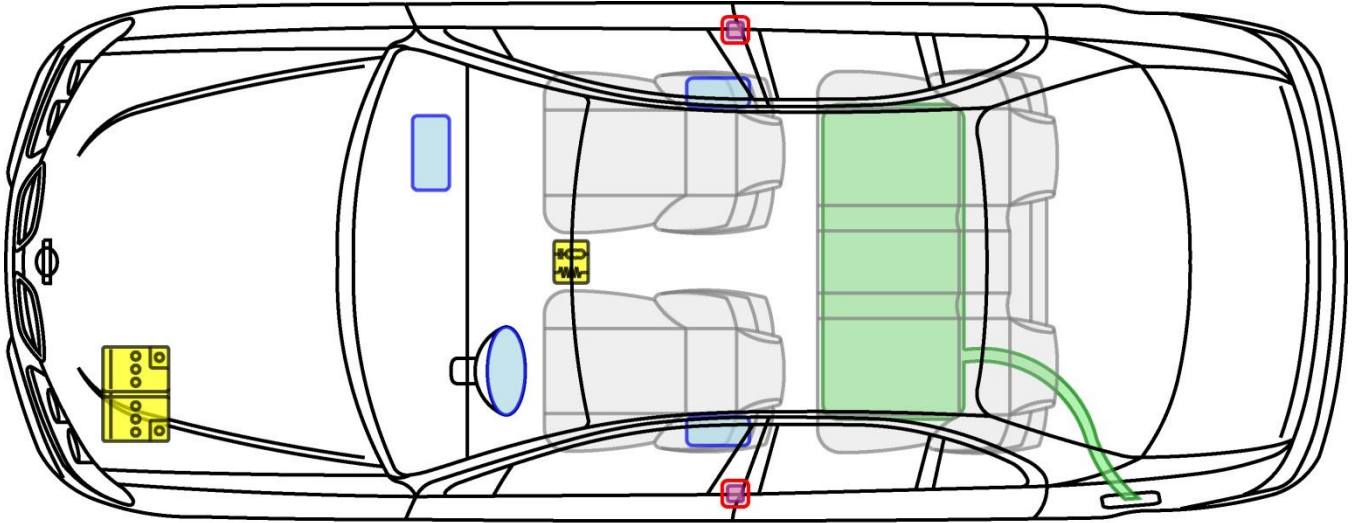

# ALMERA 4-Türer

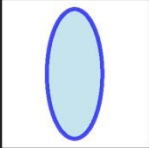
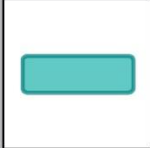
Typ: N16, 1995-2007

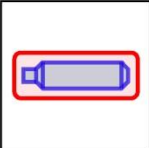

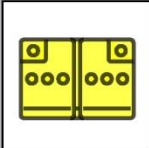
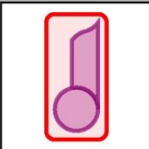
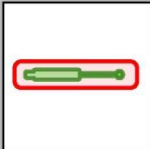
## Legende

	Airbag		Karosserie- verstärkung		Steuergerät
	Gas- generator		Überroll- schutz		Batterie
	Gurt- straffer		Gasdruck- dämpfer		Kraftstoff- tank

ALMERA









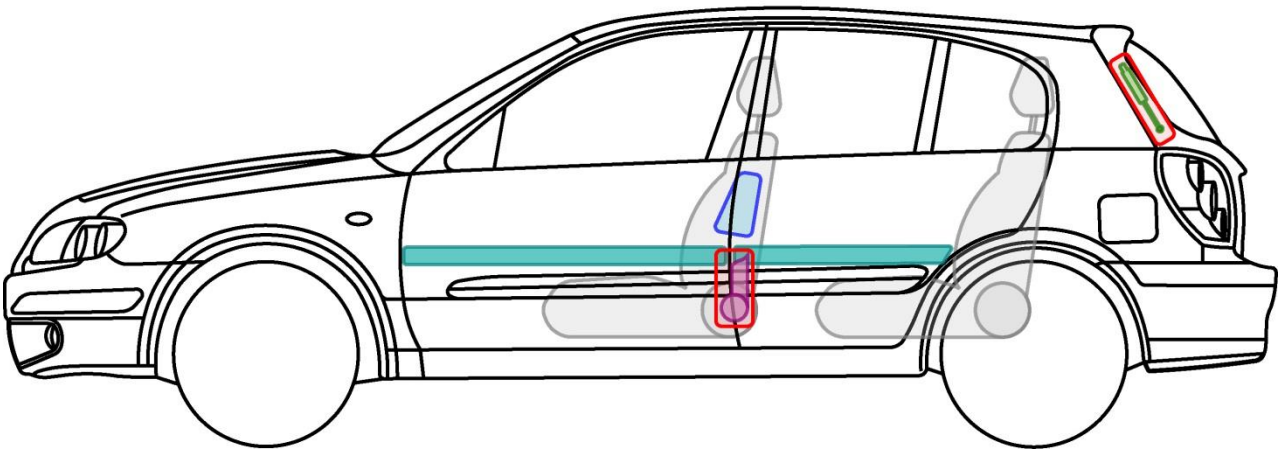
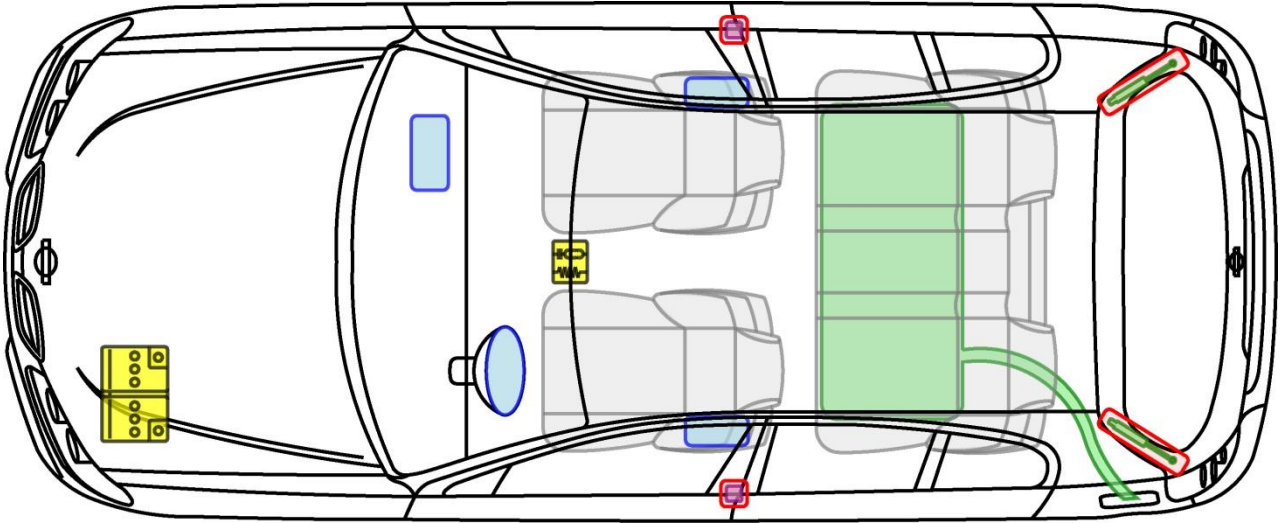

# ALMERA 5-Türer

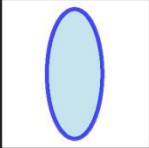
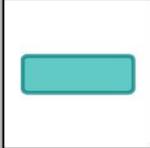
Typ: N16, 1995-2007

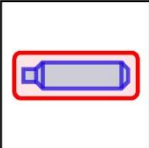

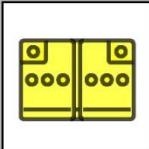
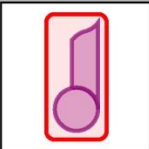
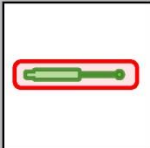
## Legende

	Airbag		Karosserie- verstärkung		Steuergerät
	Gas- generator		Überroll- schutz		Batterie
	Gurt- straffer		Gasdruck- dämpfer		Kraftstoff- tank

ALMERA









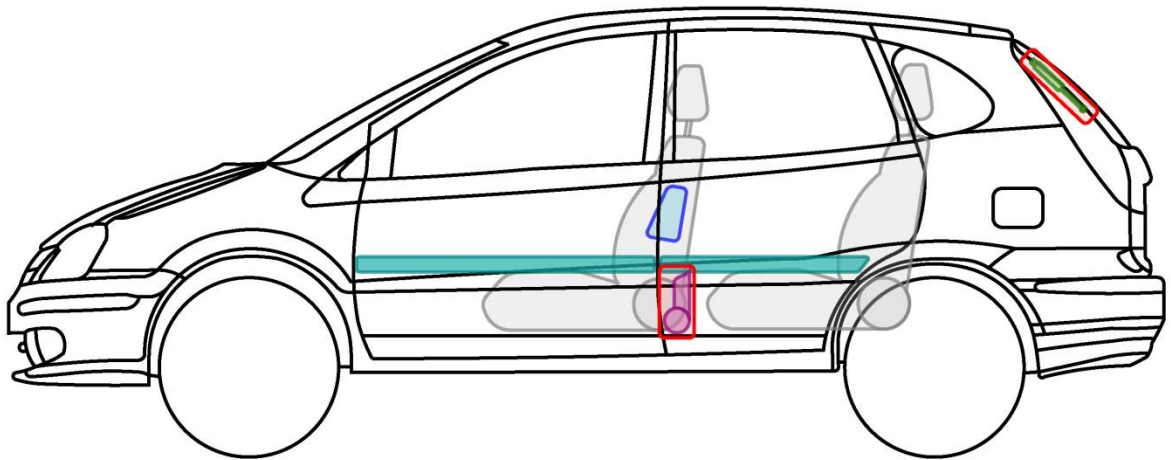
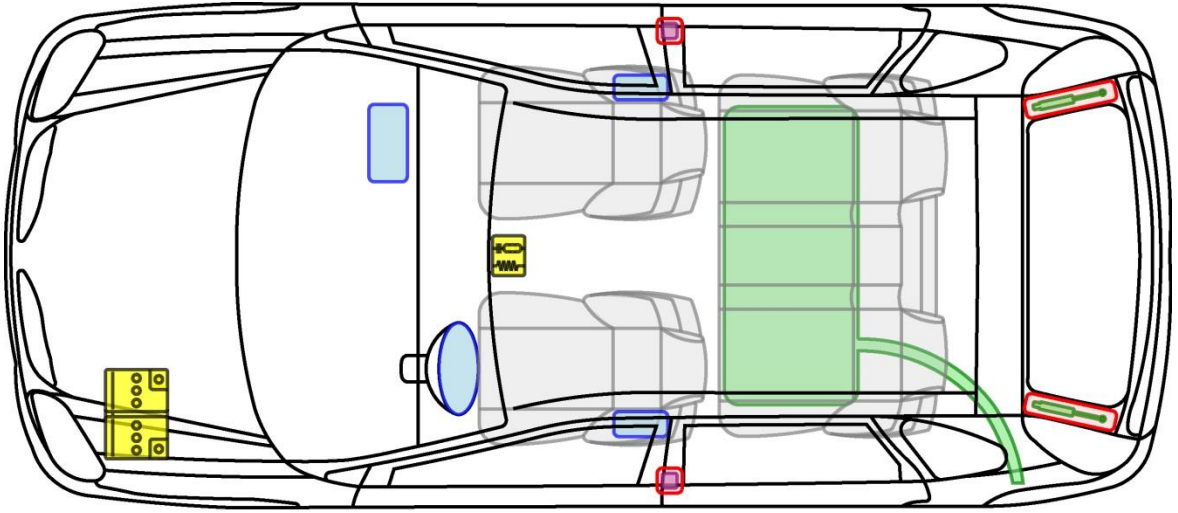

# ALMERA TINO

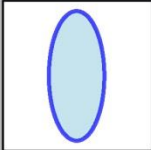
Typ: V10, 2000-2006

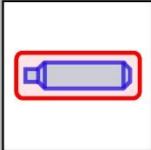

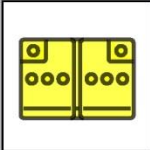
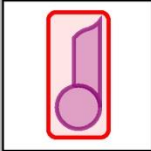
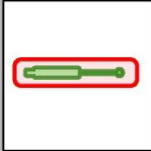
## Legende

	Airbag		Karosserie-verstärkung		Steuergerät
	Gas-generator		Überroll-schutz		Batterie
	Gurt-straffer		Gasdruck-dämpfer		Kraftstoff-tank

ALMERA TINO







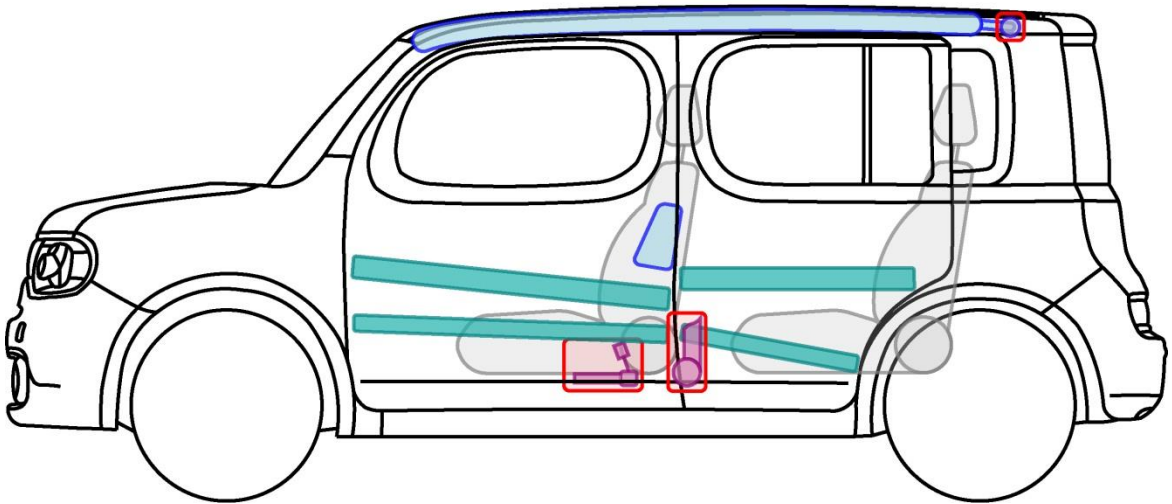
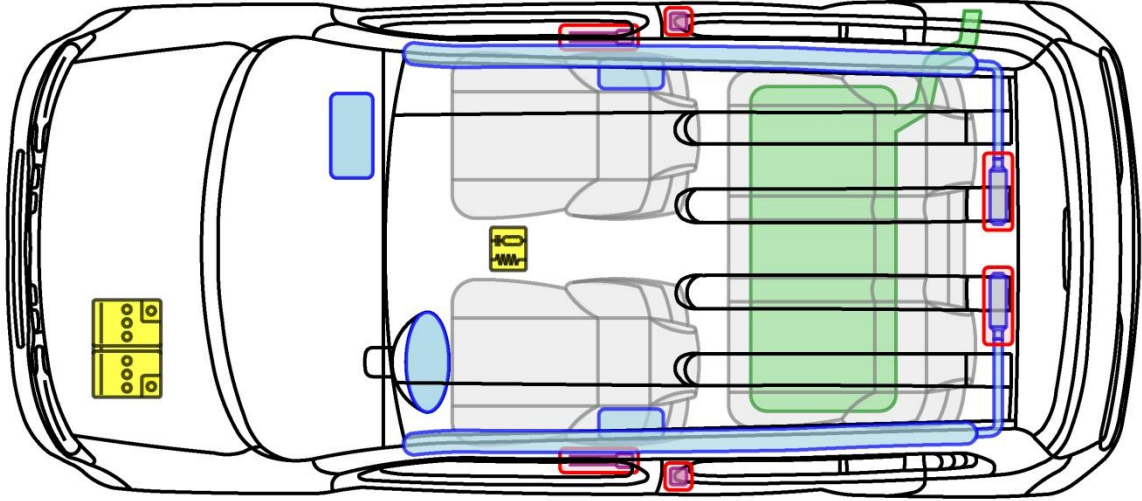

# CUBE

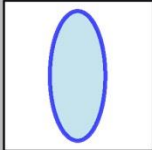
Typ: Z12, 2010-2011

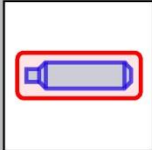
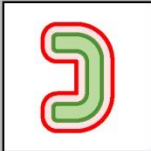
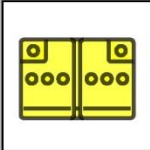

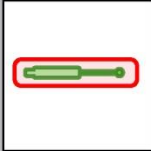
## Legende

	Airbag		Karosserie- verstärkung		Steuergerät
	Gas- generator		Überroll- schutz		Batterie
	Gurt- straffer		Gasdruck- dämpfer		Kraftstoff- tank





# e-NV200

Typ: ME0M, 2014-

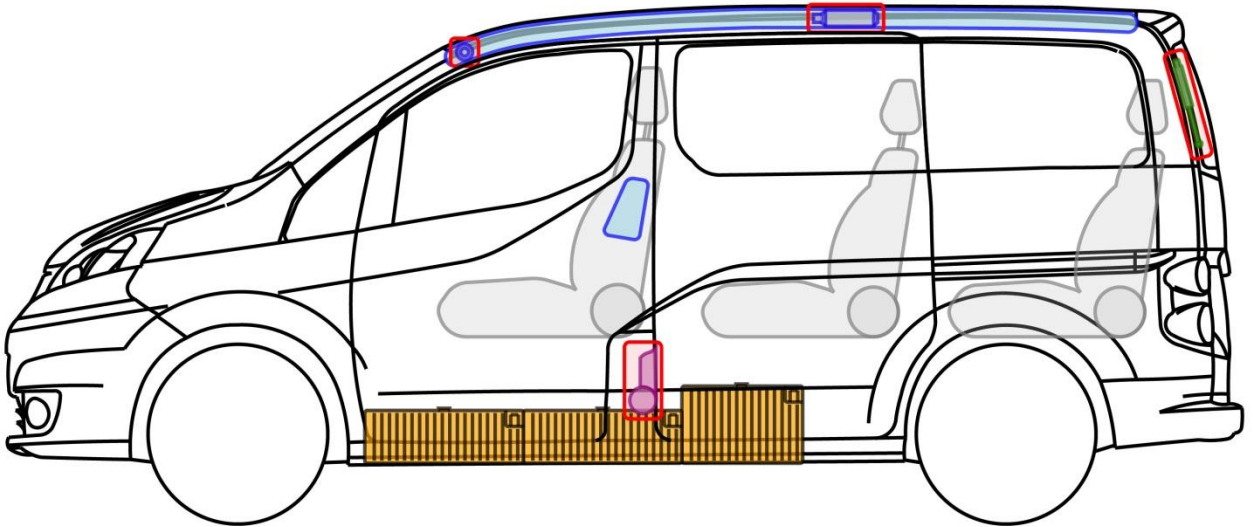
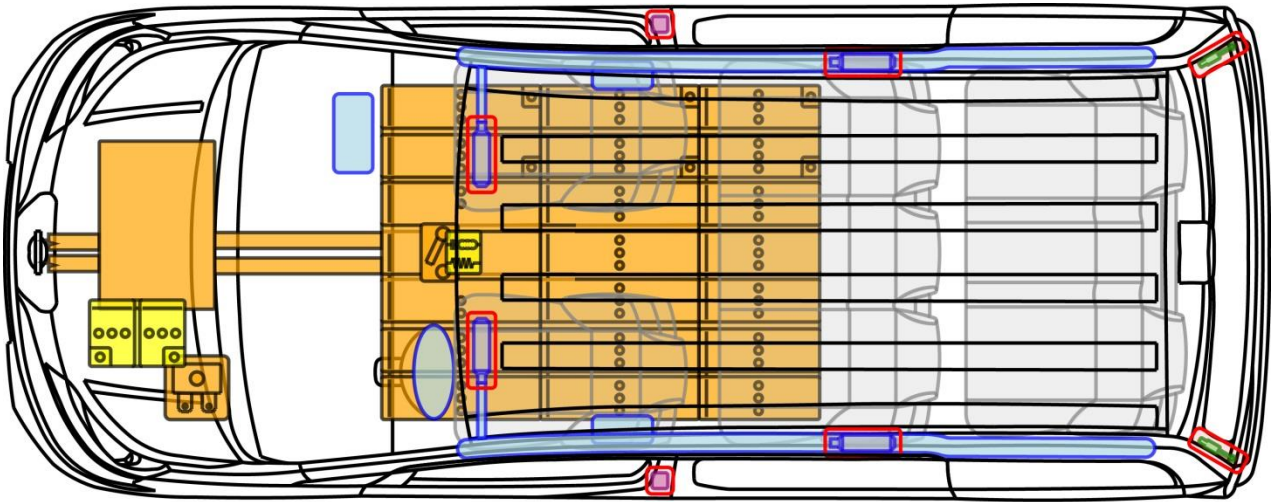

## Legende

	Airbag		Karosserieverstärkung		Steuergerät		Hochvoltleitung/-komponente
	Gas-generator		Überrollschutz		12 V Batterie		HV-Trennstelle
	Gurtstraffer		Gasdruckdämpfer		Hochvoltbatterie		Sicherungskasten
	Kraftstofftank						

e-NV200





# e-NV200

Typ: ME0M, 2014-



## Allgemeine Hinweise

- Bei Unfällen mit Airbag und/oder Gurtstrafferauslösung wird der Fahrzeugantrieb automatisch deaktiviert. Die Rückhaltesysteme sind weiterhin aktiv.
- Die Zeit bis zur vollständigen Deaktivierung des Antriebs beträgt **10 Minuten** nach Durchführung der Deaktivierungsschritte.
- **Vor Beginn von Arbeiten am Fahrzeug Ladestecker ziehen!**
- **Schutzausrüstung erforderlich (Isolierende Handschuhe bis 1000 V, Gesichtsschutz).**

## Fahrzeug gegen wegrollen sichern

- Räder unterkeilen.
- Feststellbremse betätigen.

## Deaktivieren von Hochvolt- (HV) und Rückhaltesystem (SRS)

### Methode 1

1. Prüfen ob das Hochvoltssystem eingeschaltet ist. Symbol: 
2. Ist das System aktiv, Start-Stopp Knopf einmal betätigen.
3. 12 Volt Batterie abklemmen. Massekabel zuerst.







# e-NV200

Typ: ME0M, 2014-



## Deaktivieren von Hochvolt- (HV) und Rückhaltesystem (SRS)

### Methode 2

1. Sicherungskasten lokalisieren und öffnen.



2. Dargestellte Sicherungen entfernen.



1. 12 Volt Batterie abklemmen. Massekabel zuerst.





# e-NV200

Typ: ME0M, 2014-



## Deaktivierung des Hochvoltsystem (HV)

### Methode 3

1. HV-Trennstelle lokalisieren, Abdeckung entfernen.
2. Verkleidungsteil abschrauben und nach oben abheben.
3. Abdeckung öffnen, z.B. durch Abschrauben (Schlüsselweite 10 mm) oder aufhebeln.
4. Servicestecker wie dargestellt entfernen!  
**Schutzausrüstung erforderlich (Isolierende Handschuhe bis 1000 V, Gesichtsschutz).**

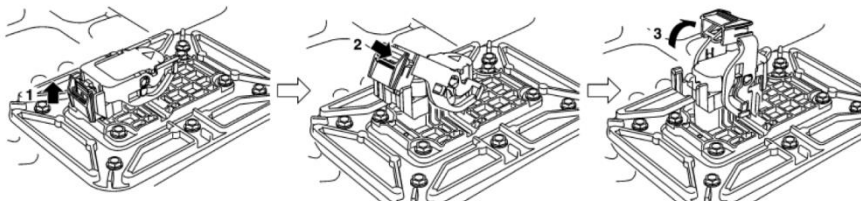
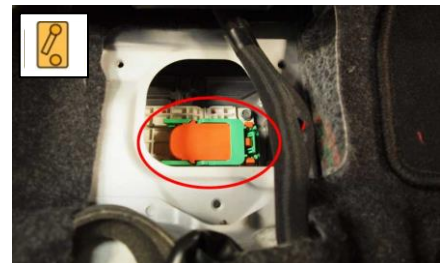

- **Kann die 12 Volt Batterie nicht abgeklemmt werden, sind die Rückhaltesysteme weiterhin aktiv!**



# EVALIA

Typ: M20M, 2011-

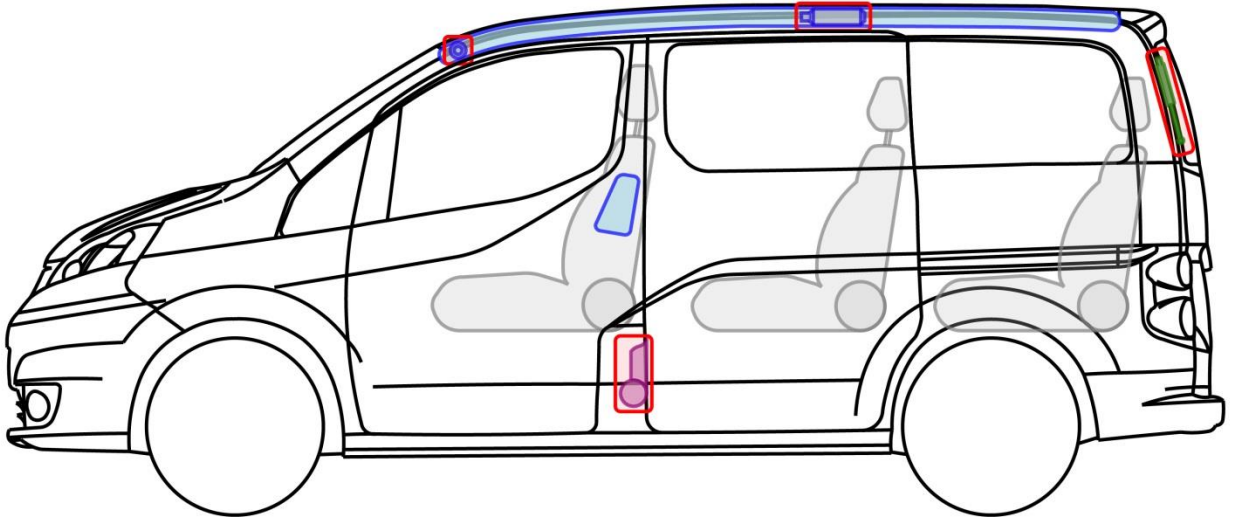
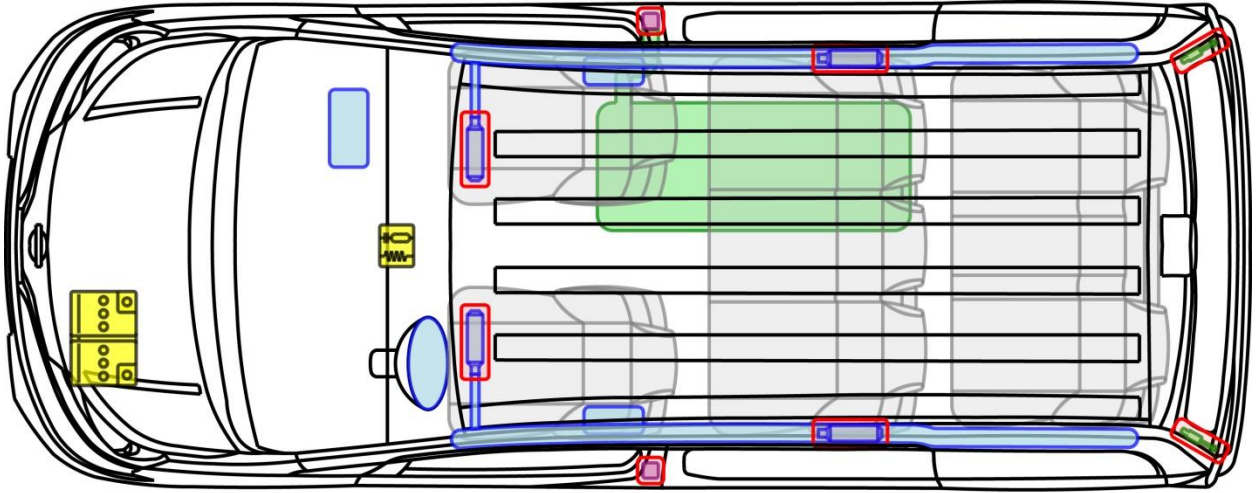

## Legende

	Airbag		Karosserie- verstärkung		Steuergerät
	Gas- generator		Überroll- schutz		Batterie
	Gurt- straffer		Gasdruck- dämpfer		Kraftstoff- tank









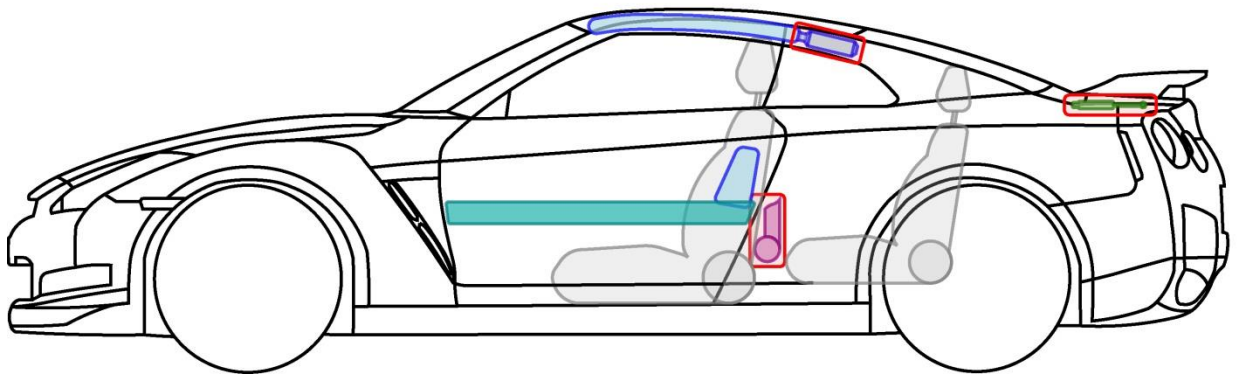
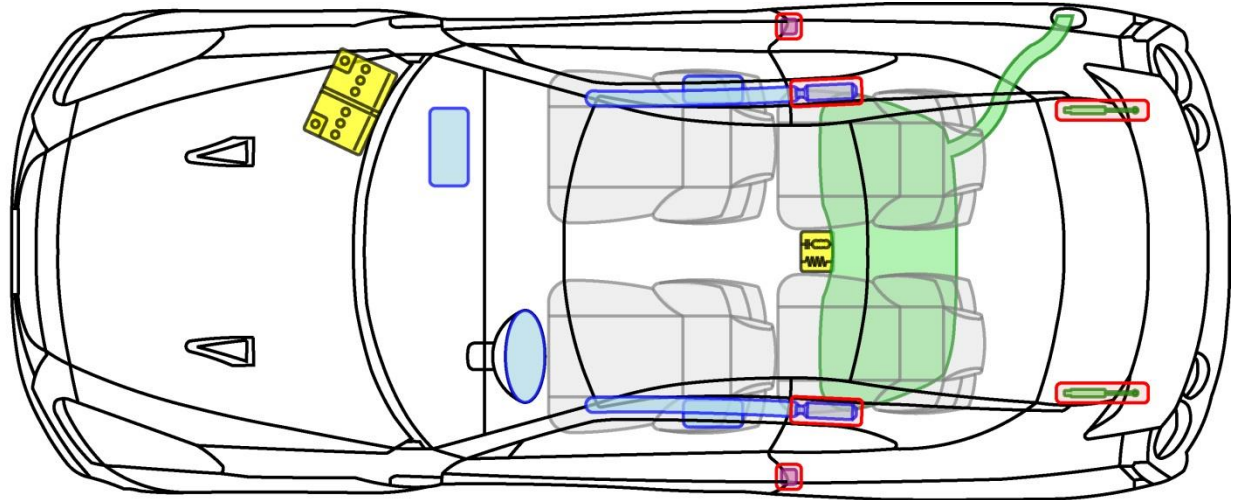

# GT-R

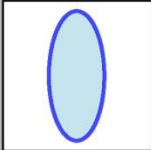
Typ: R35, 2008-

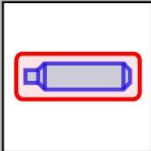

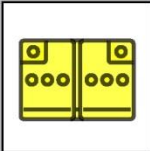
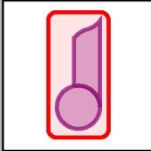
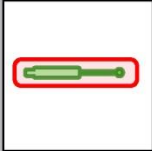
## Legende

	Airbag		Karosserie- verstärkung		Steuergerät
	Gas- generator		Überroll- schutz		Batterie
	Gurt- straffer		Gasdruck- dämpfer		Kraftstoff- tank

GT-R









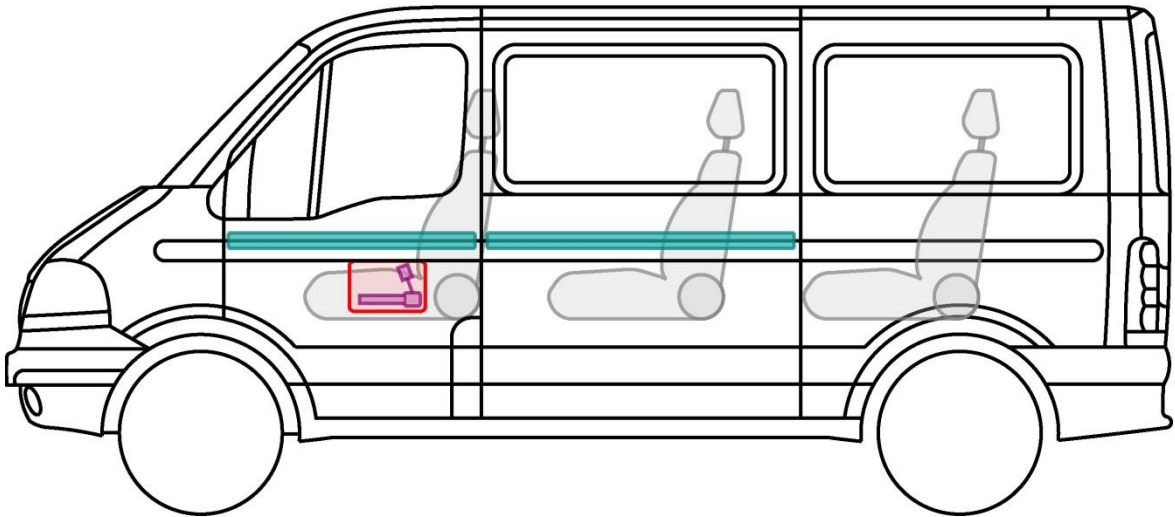
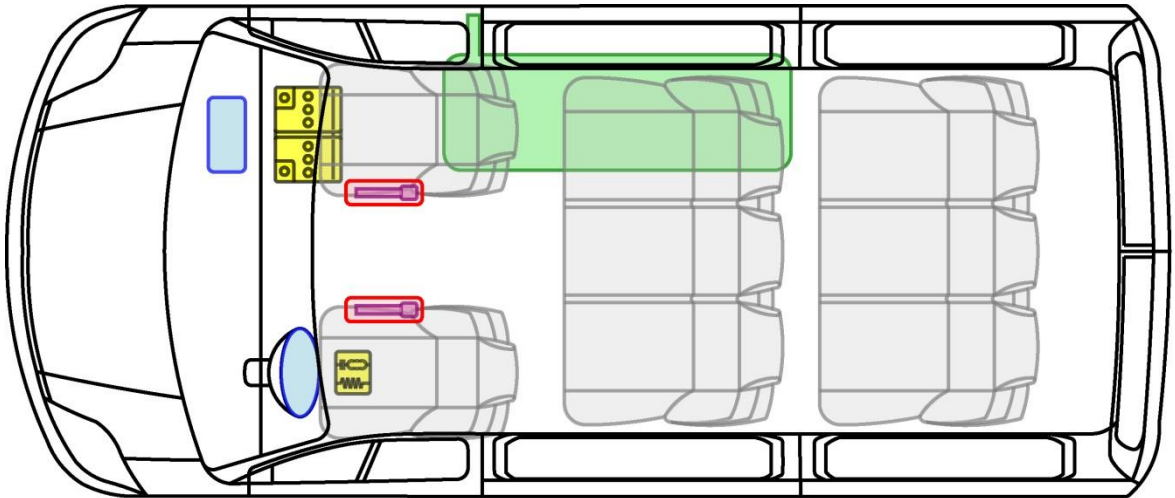

# INTERSTAR

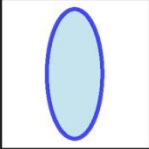
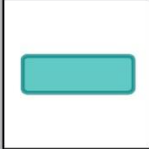
Typ: X70, 2004-2010

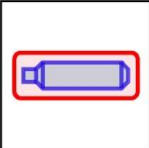

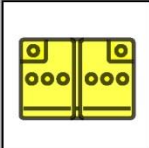
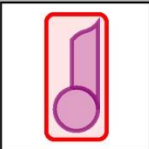
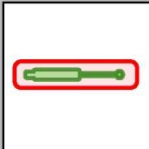
## Legende

	Airbag		Karosserie- verstärkung		Steuergerät
	Gas- generator		Überroll- schutz		Batterie
	Gurt- straffer		Gasdruck- dämpfer		Kraftstoff- tank

INTERSTAR







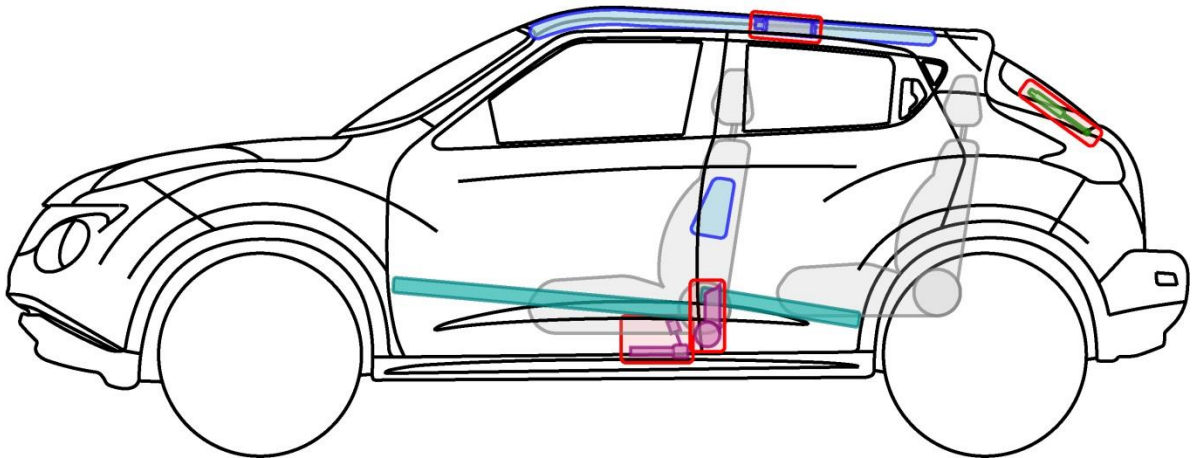
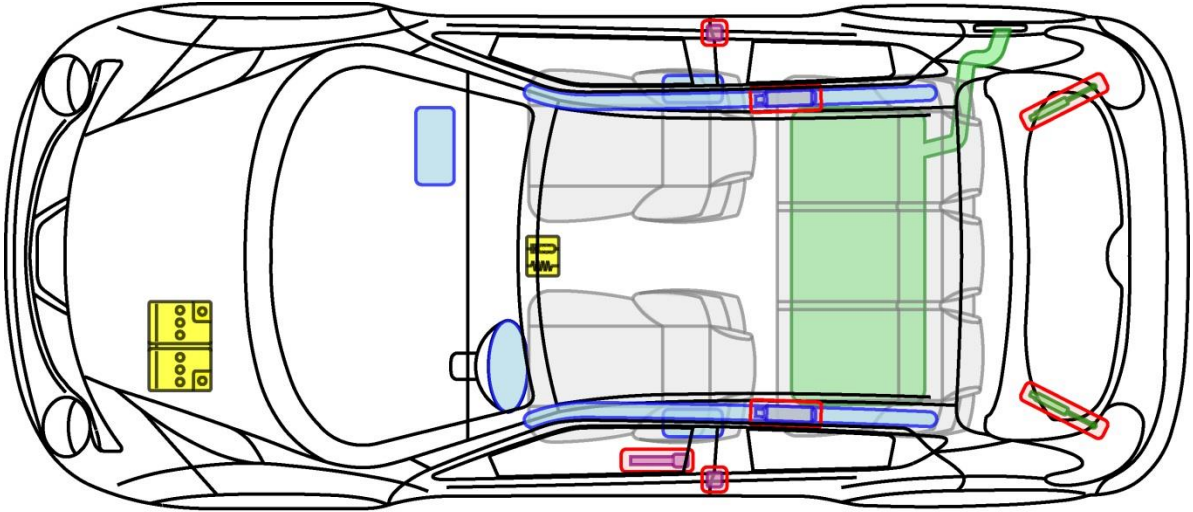

# JUKE

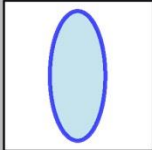
Typ: F15, 2010-

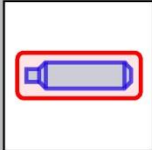
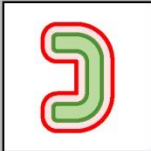
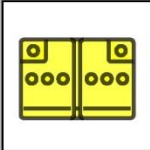

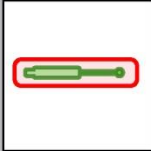
## Legende

	Airbag		Karosserie- verstärkung		Steuergerät
	Gas- generator		Überroll- schutz		Batterie
	Gurt- straffer		Gasdruck- dämpfer		Kraftstoff- tank





# LEAF

Typ: ZE0, 2011-2013  
JN1FAAZE0Uxxxxxxx

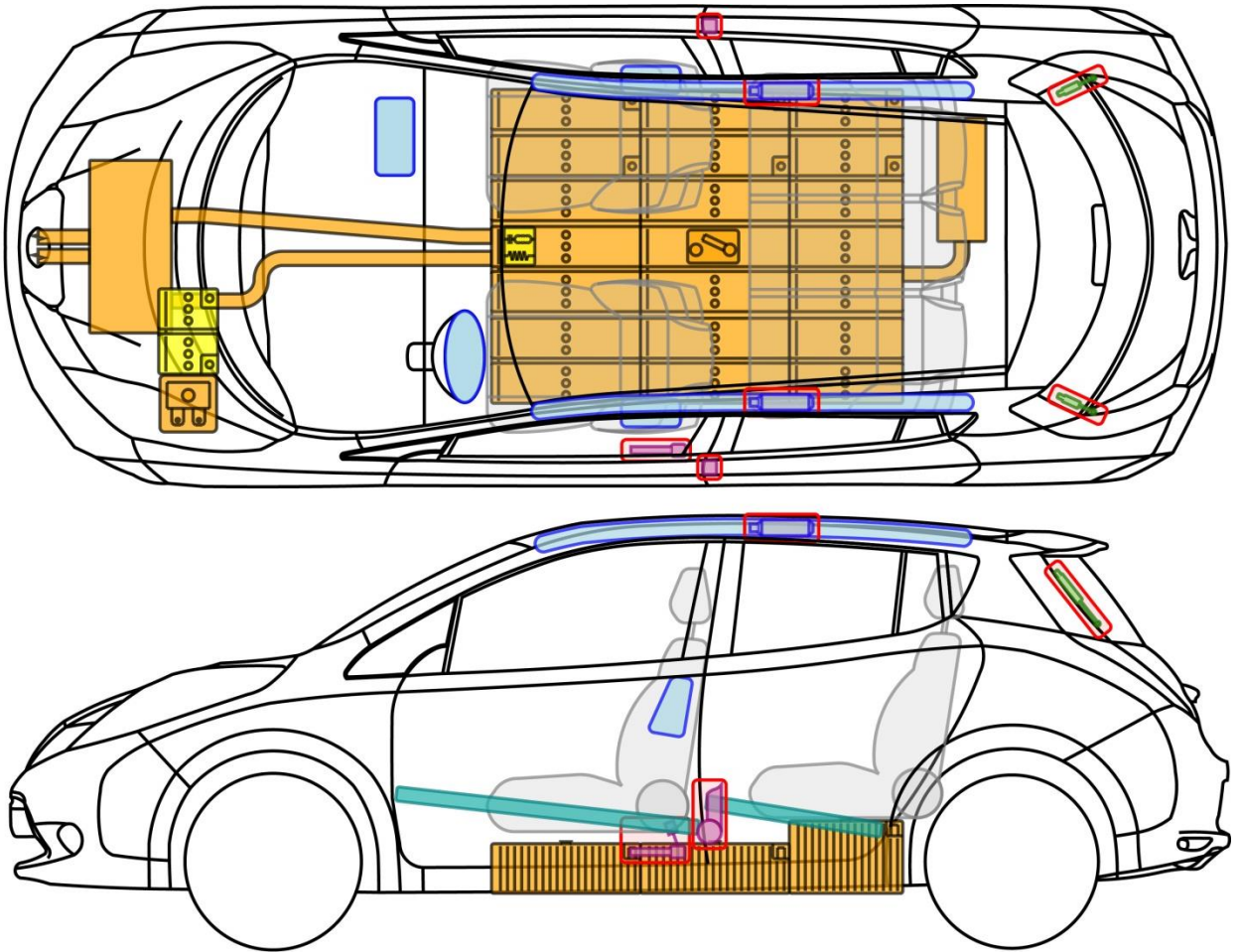

## Legende

	Airbag		Karosserieverstärkung		Steuergerät		Hochvoltleitung/-komponente
	Gas-generator		Überrollschutz		12 V Batterie		HV-Trennstelle
	Gurtstraffer		Gasdruckdämpfer		Hochvoltbatterie		Sicherungskasten
	Kraftstofftank						







# LEAF

Typ: ZE0, 2011-2013  
JN1FAAZE0Uxxxxxxx



## Allgemeine Hinweise

- Bei Unfällen mit Airbag und/oder Gurtstrafferauslösung wird der Fahrzeugantrieb automatisch deaktiviert. Die Rückhaltesysteme sind weiterhin aktiv.
- Die Zeit bis zur vollständigen Deaktivierung des Antriebs beträgt **10 Minuten** nach Durchführung der Deaktivierungsschritte.
- **Vor Beginn von Arbeiten am Fahrzeug Ladestecker ziehen!**
- **Schutzausrüstung erforderlich (Isolierende Handschuhe bis 1000 V, Gesichtsschutz).**

## Fahrzeug gegen wegrollen sichern

- Räder unterkeilen.
- Bremse betätigen
- Schalter der elektrische Parkbremse nach oben ziehen.



## Deaktivieren von Hochvolt- (HV) und Rückhaltesystem (SRS)

### Methode 1

1. Prüfen ob das Hochvoltsystem eingeschaltet ist. Symbol: 
2. Ist das System aktiv, Start-Stopp Knopf einmal betätigen.
3. 12 Volt Batterie abklemmen. Massekabel zuerst.







# LEAF

Typ: ZE0, 2011-2013  
JN1FAAZE0Uxxxxxxx



## Deaktivieren von Hochvolt- (HV) und Rückhaltesystem (SRS)

### Methode 2

1. Sicherungskasten lokalisieren und öffnen.



2. Dargestellte Sicherungen im Kastendeckel entfernen.

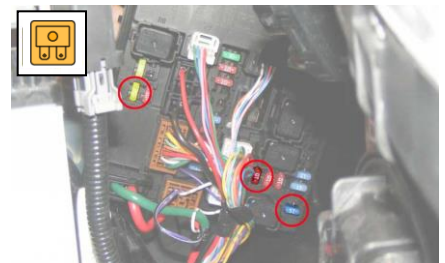

3. 12 Volt Batterie abklemmen. Massekabel zuerst.





# LEAF

Typ: ZE0, 2011-2013  
JN1FAAZE0Uxxxxxxx



## Deaktivierung des Hochvoltsystem (HV)

### Methode 3

1. HV-Trennstelle lokalisieren.
2. Abdeckung öffnen, z.B. durch abschrauben (Schlüsselweite 10 mm) oder aufhebeln.
3. Servicestecker wie dargestellt entfernen!

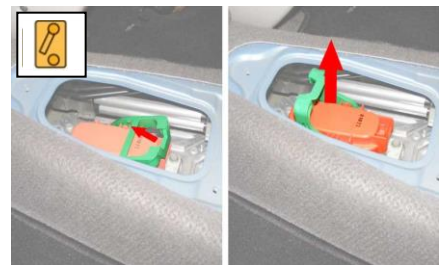
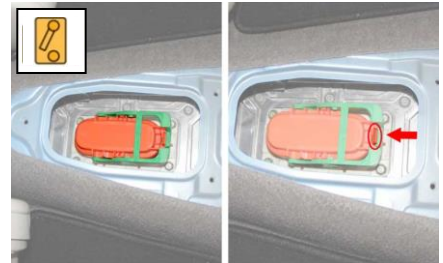

- **Kann die 12 Volt Batterie nicht abgeklemmt werden, sind die Rückhaltesysteme weiterhin aktiv!**



# LEAF

Typ: ZE0, 2013-  
SJNFAAZE0Uxxxxxxx

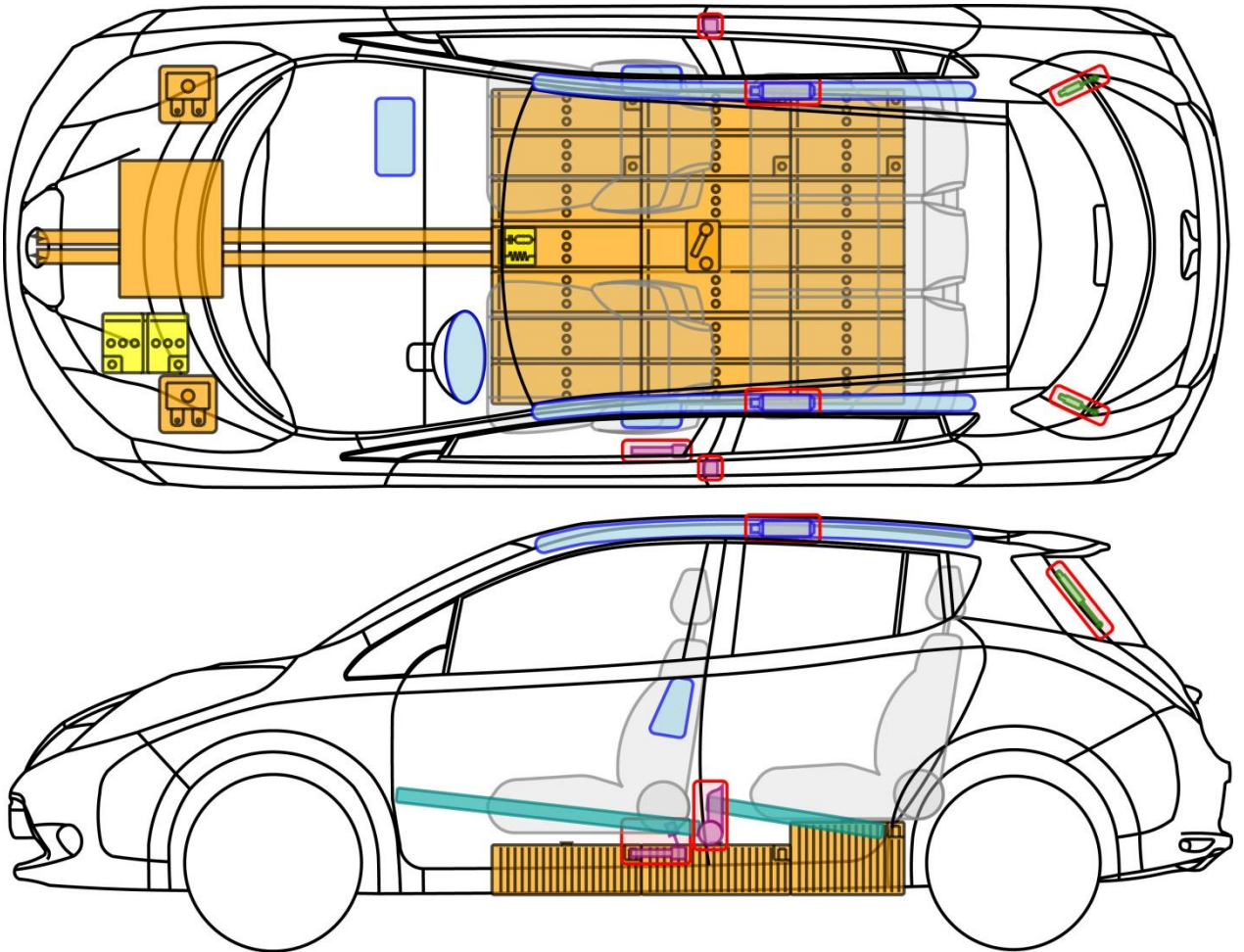

## Legende

	Airbag		Karosserie-verstärkung		Steuergerät		Hochvolt-leitung/-komponente
	Gas-generator		Überroll-schutz		12 V Batterie		HV-Trennstelle
	Gurt-straffer		Gasdruck-dämpfer		Hochvolt-batterie		Sicherungs-kasten
	Kraftstoff-tank						





# LEAF

Typ: ZE0, 2013-  
SJNFAAZE0Uxxxxxxx



## Allgemeine Hinweise

- Bei Unfällen mit Airbag und/oder Gurtstrafferauslösung wird der Fahrzeugantrieb automatisch deaktiviert. Die Rückhaltesysteme sind weiterhin aktiv.
- Die Zeit bis zur vollständigen Deaktivierung des Antriebs beträgt **10 Minuten** nach Durchführung der Deaktivierungsschritte.
- **Vor Beginn von Arbeiten am Fahrzeug Ladestecker ziehen!**
- **Schutzausrüstung erforderlich (Isolierende Handschuhe bis 1000 V, Gesichtsschutz).**

## Fahrzeug gegen wegrollen sichern

- Räder unterkeilen.
- Fußfeststellbremse betätigen.

## Deaktivieren von Hochvolt- (HV) und Rückhaltesystem (SRS)

### Methode 1

1. Prüfen ob das Hochvoltsystem eingeschaltet ist. Symbol: 
2. Ist das System aktiv, Start-Stopp Knopf einmal betätigen.
3. 12 Volt Batterie abklemmen. Massekabel zuerst.







# LEAF

Typ: ZE0, 2013-

SJNFAAZE0Uxxxxxxx



## Deaktivieren von Hochvolt- (HV) und Rückhaltesystem (SRS)

### Methode 2

1. Sicherungskasten 1 lokalisieren und öffnen.



2. Dargestellte Sicherungen im Kastendeckel entfernen.



3. Sicherungskasten 2 lokalisieren und öffnen.



4. Dargestellte Sicherung im Kastendeckel entfernen.



5. 12 Volt Batterie abklemmen. Massekabel zuerst.





# LEAF

Typ: ZE0, 2013-

SJNFAAZE0Uxxxxxxx



## Deaktivierung des Hochvoltsystem (HV)

### Methode 3

1. HV-Trennstelle lokalisieren.
2. Abdeckung öffnen, z.B. durch abschrauben (Schlüsselweite 10 mm) oder aufhebeln.
3. Servicestecker wie dargestellt entfernen!



- **Kann die 12 Volt Batterie nicht abgeklemmt werden, sind die Rückhaltesysteme weiterhin aktiv!**







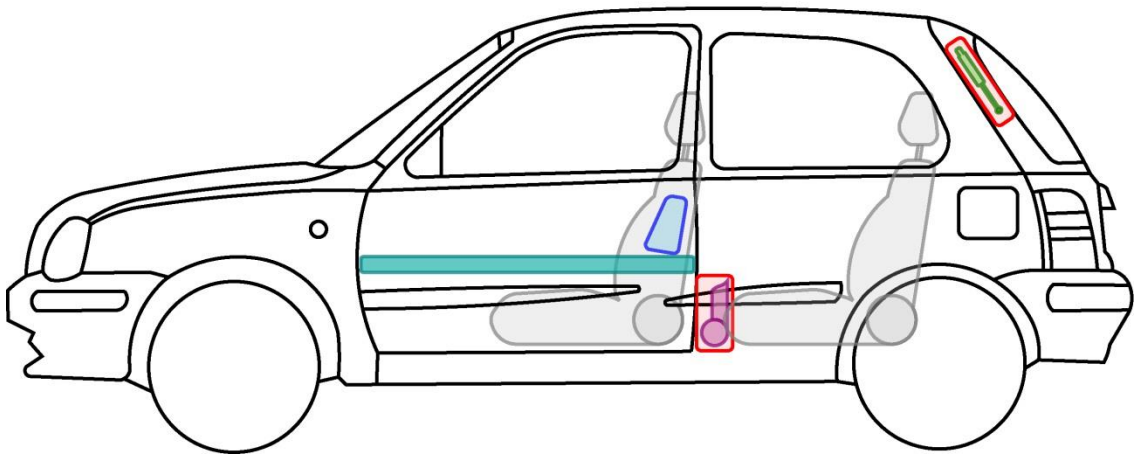
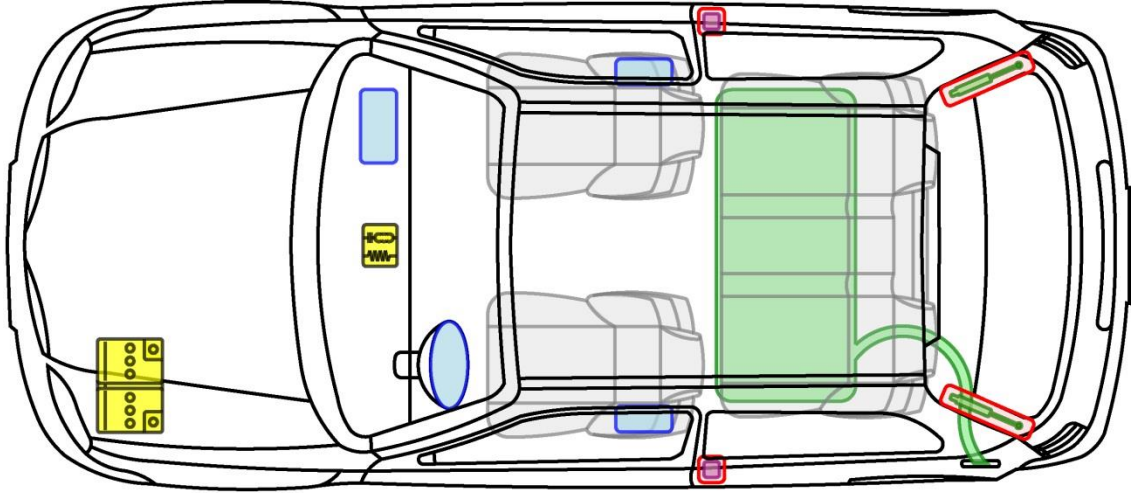

# MICRA 3-Türer

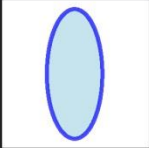
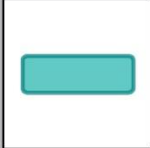
Typ: K11, 1996-2003

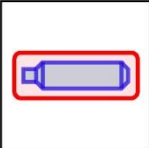

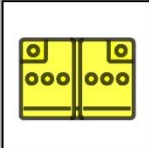
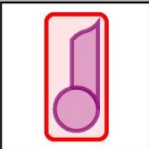
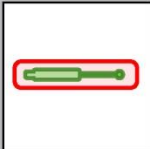
## Legende

	Airbag		Karosserie- verstärkung		Steuergerät
	Gas- generator		Überroll- schutz		Batterie
	Gurt- straffer		Gasdruck- dämpfer		Kraftstoff- tank

MICRA







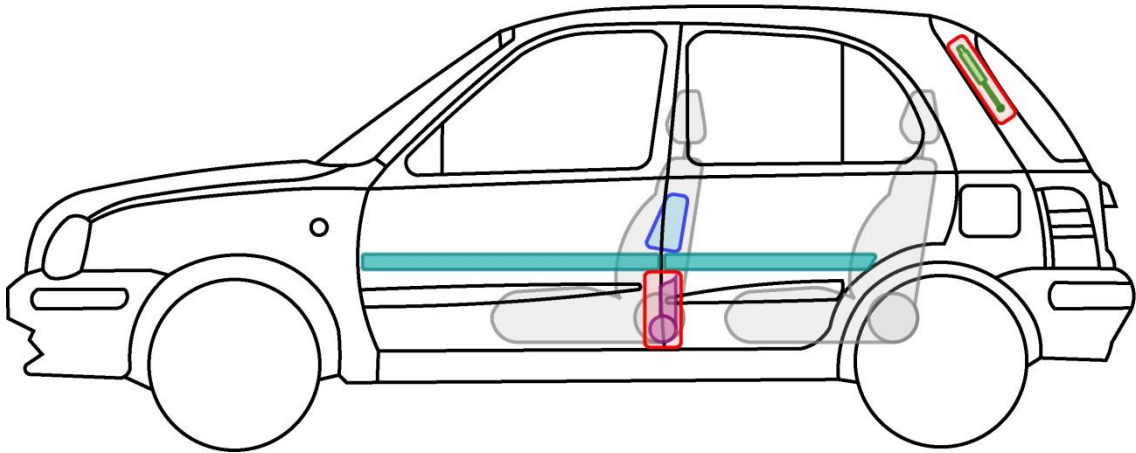
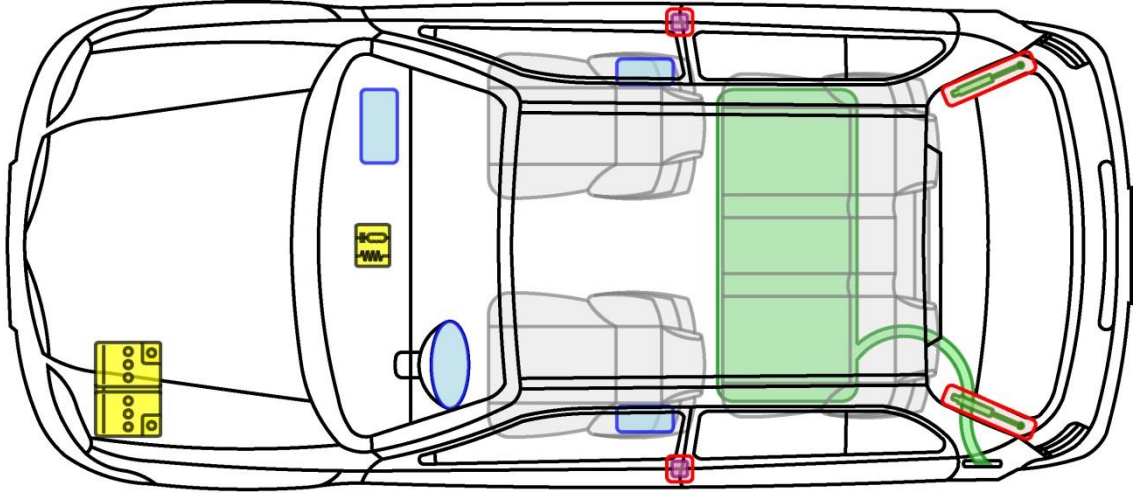

# MICRA 5-Türer

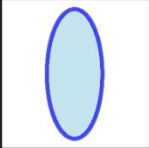
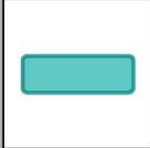
Typ: K11, 1996-2003

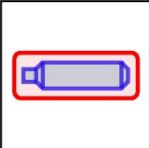

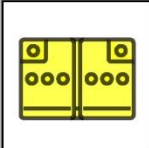
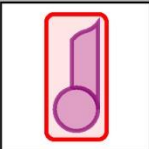
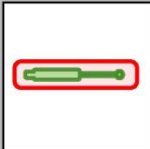
## Legende

	Airbag		Karosserie- verstärkung		Steuergerät
	Gas- generator		Überroll- schutz		Batterie
	Gurt- straffer		Gasdruck- dämpfer		Kraftstoff- tank

MICRA









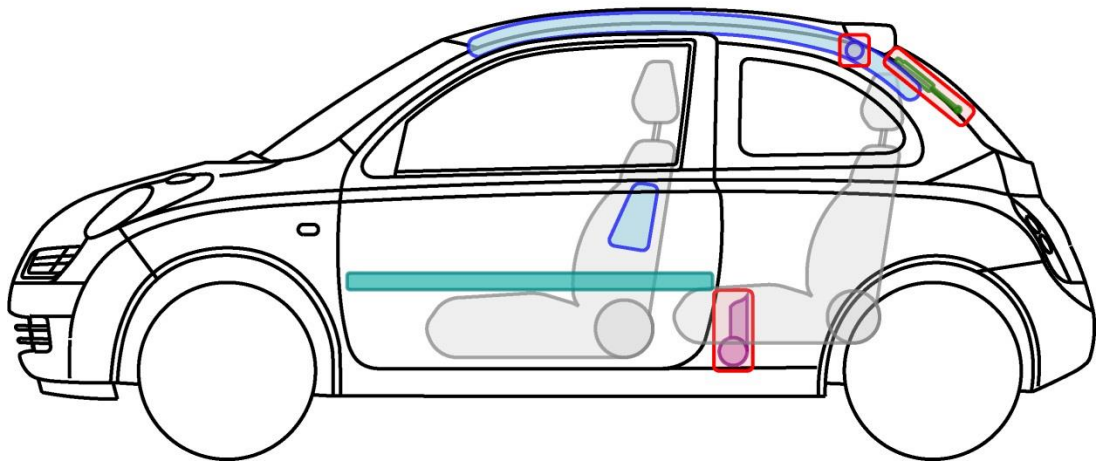
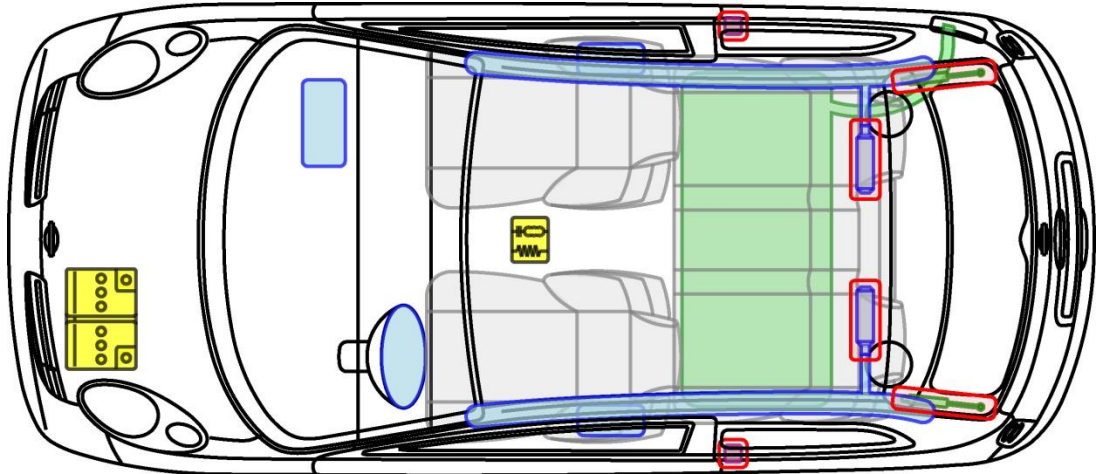

# MICRA 3-Türer

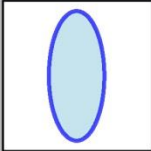
Typ: K12, 2003-2010

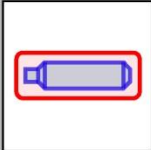

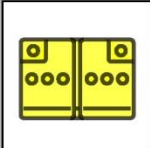
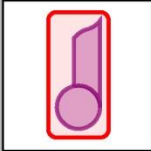
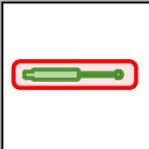
## Legende

	Airbag		Karosserie- verstärkung		Steuergerät
	Gas- generator		Überroll- schutz		Batterie
	Gurt- straffer		Gasdruck- dämpfer		Kraftstoff- tank





# MICRA 5-Türer

Typ: K12, 2003-2010

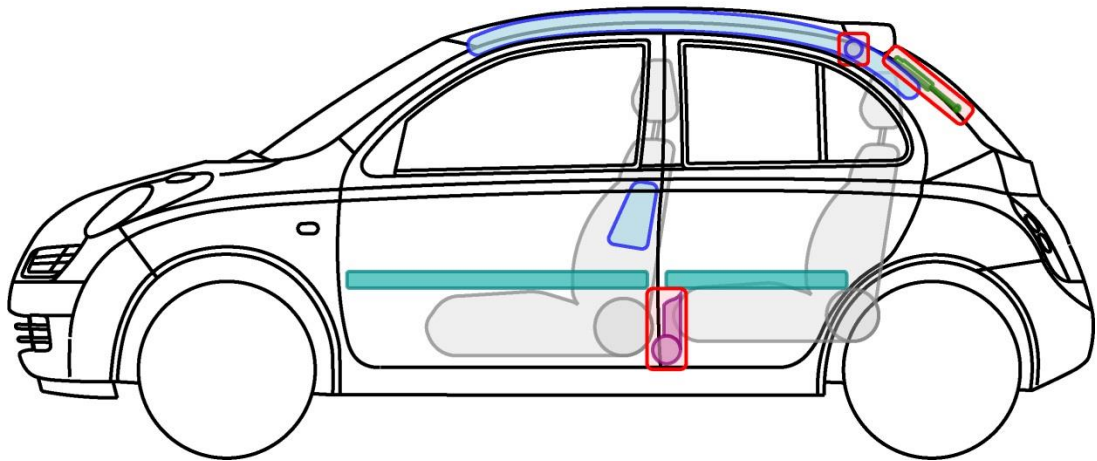
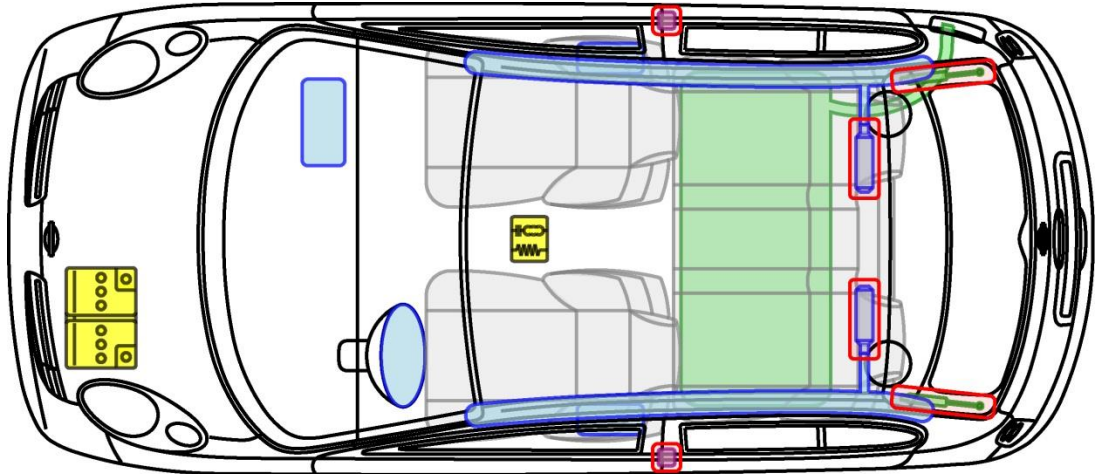

## Legende

	Airbag		Karosserie- verstärkung		Steuergerät
	Gas- generator		Überroll- schutz		Batterie
	Gurt- straffer		Gasdruck- dämpfer		Kraftstoff- tank





# MICRA C+C

Typ: K12, 2005-2009

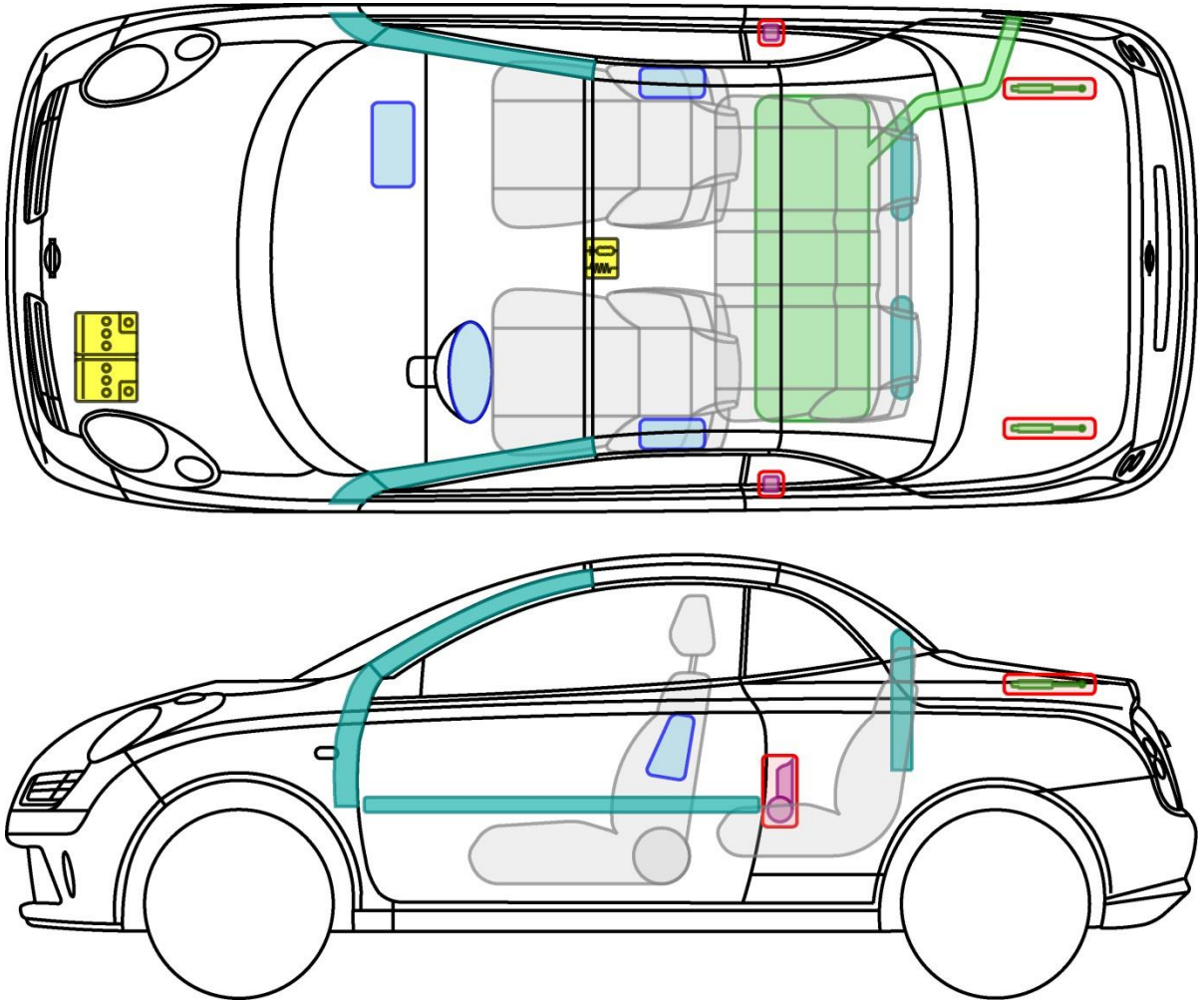

## Legende

	Airbag		Karosserie- verstärkung		Steuergerät
	Gas- generator		Überroll- schutz		Batterie
	Gurt- straffer		Gasdruck- dämpfer		Kraftstoff- tank







# MICRA 5-Türer

Typ: K13, 2010-

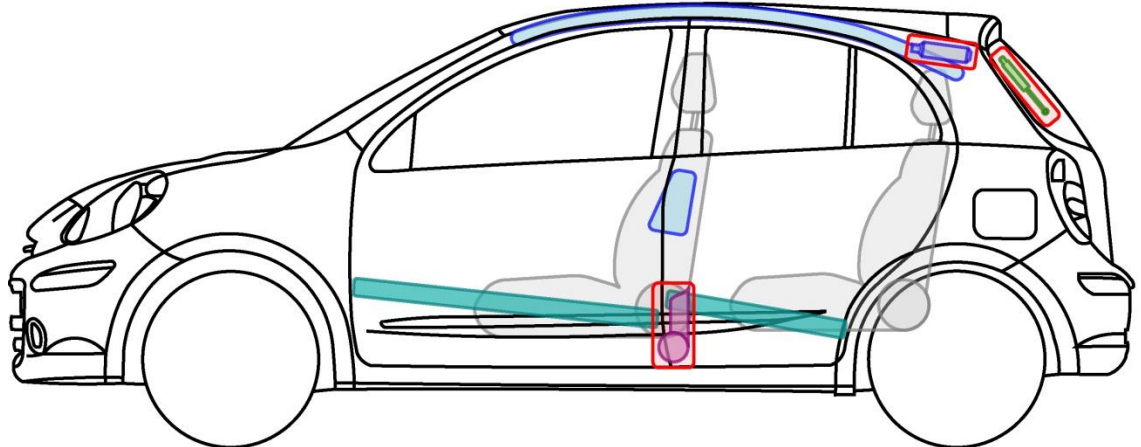
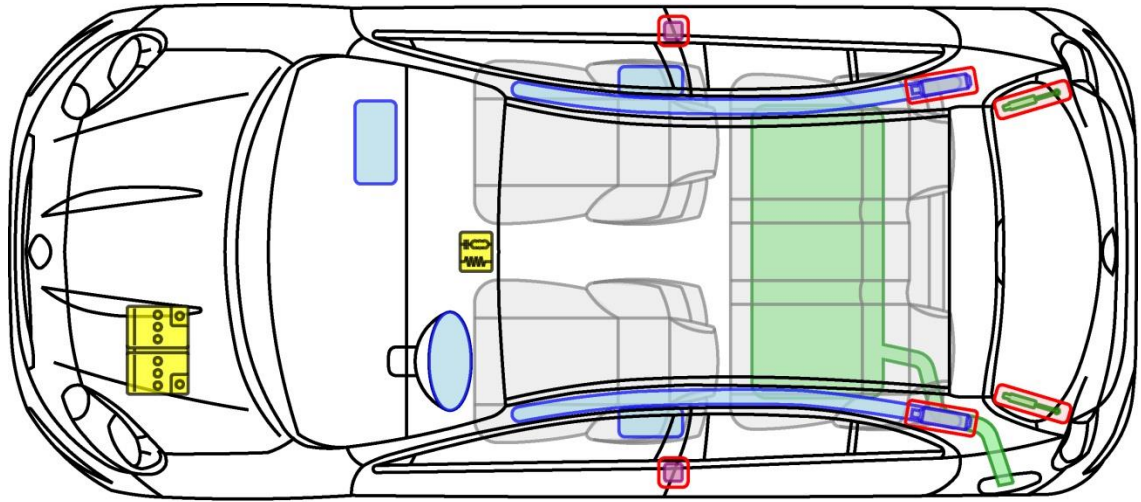

## Legende

	Airbag		Karosserie-verstärkung		Steuergerät
	Gas-generator		Überroll-schutz		Batterie
	Gurt-straffer		Gasdruck-dämpfer		Kraftstoff-tank











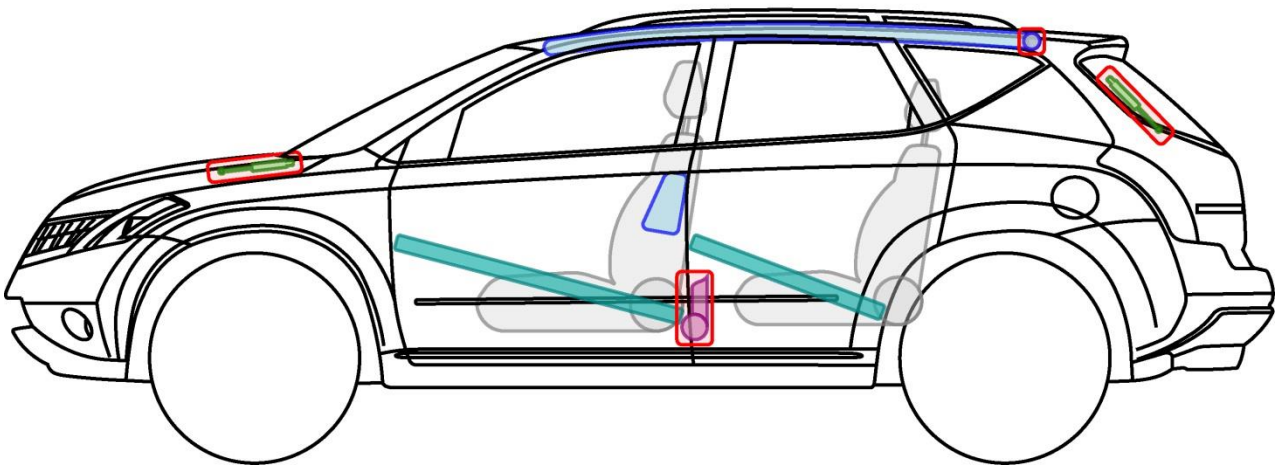
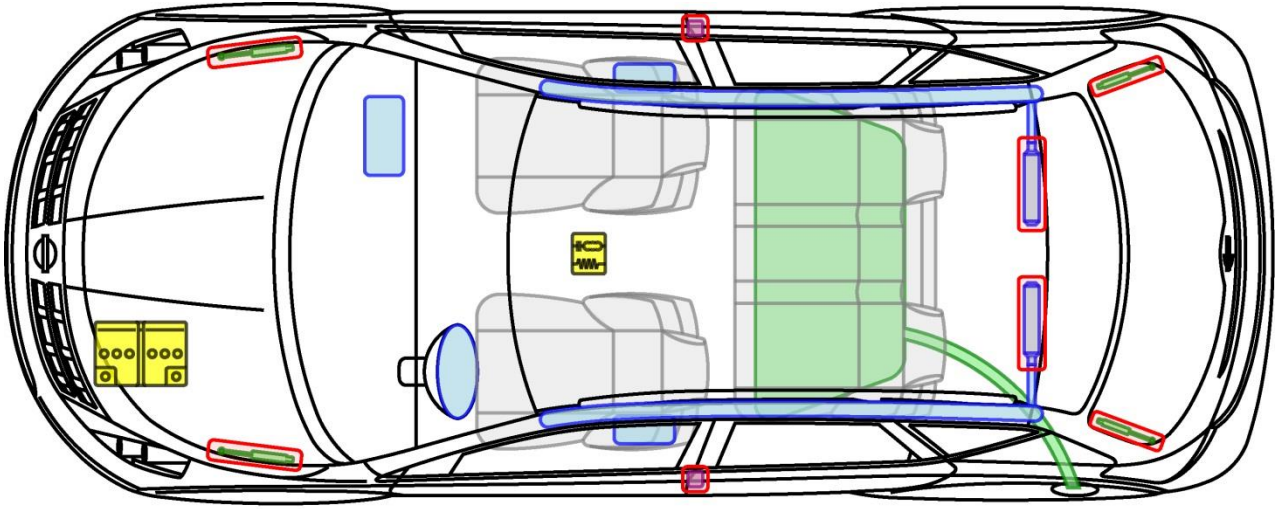

# MURANO

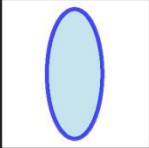
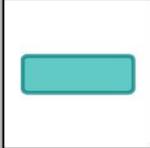
Typ: Z50, 2005-2008

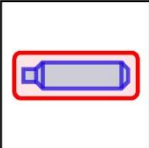

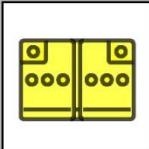
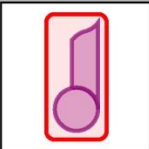
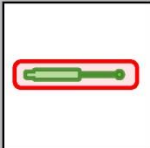
## Legende

	Airbag		Karosserie- verstärkung		Steuergerät
	Gas- generator		Überroll- schutz		Batterie
	Gurt- straffer		Gasdruck- dämpfer		Kraftstoff- tank

MURANO







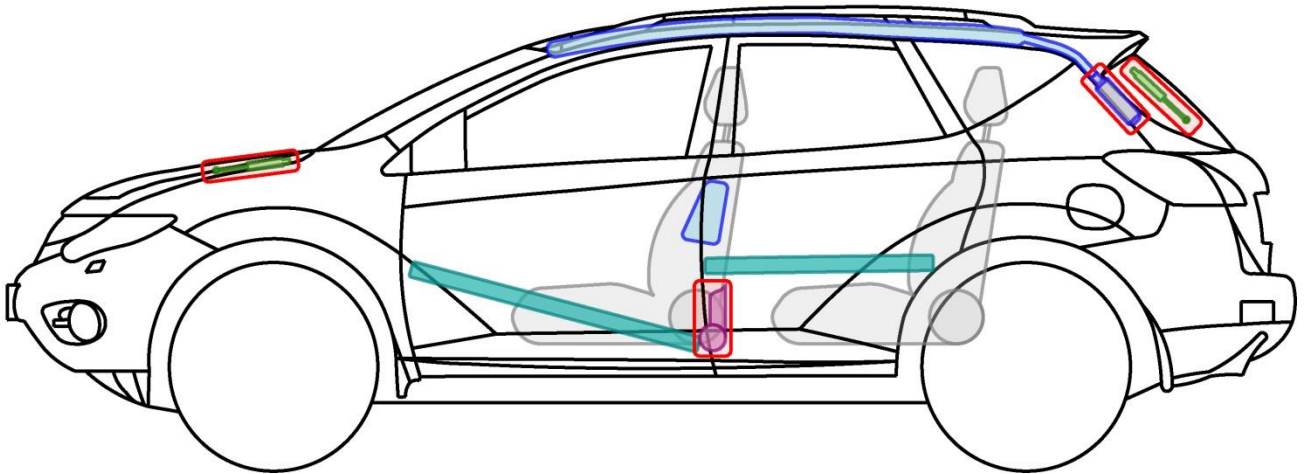
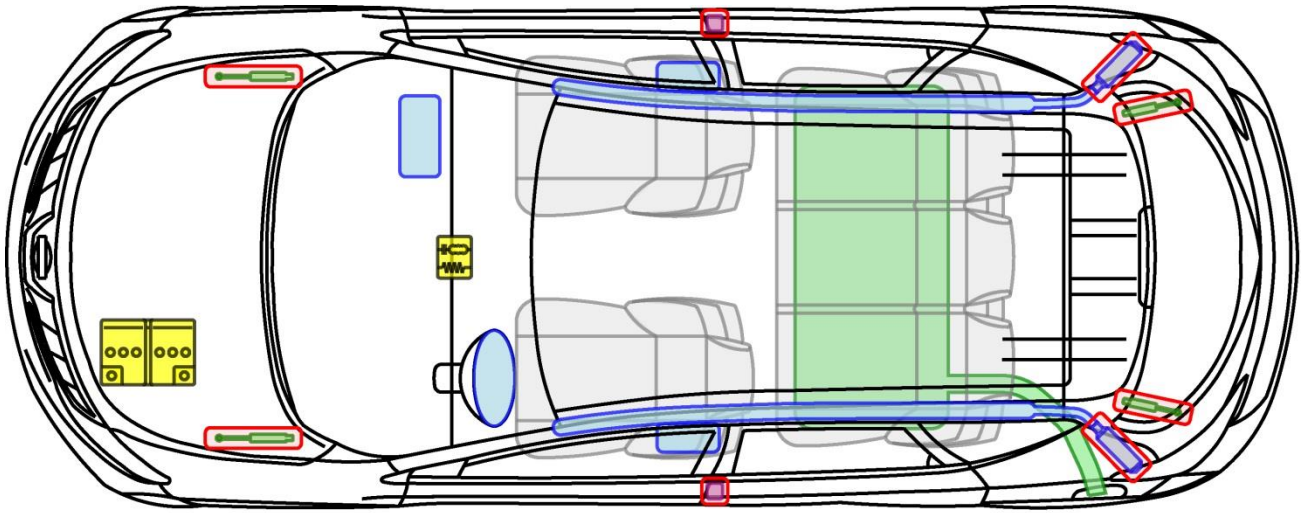

# MURANO

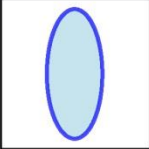
Typ: Z51, 2008-

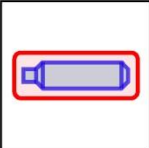

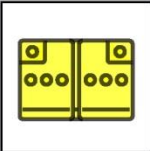
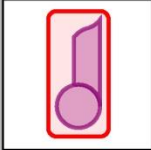
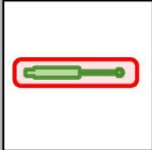
## Legende

	Airbag		Karosserie- verstärkung		Steuergerät
	Gas- generator		Überroll- schutz		Batterie
	Gurt- straffer		Gasdruck- dämpfer		Kraftstoff- tank

**MURANO**







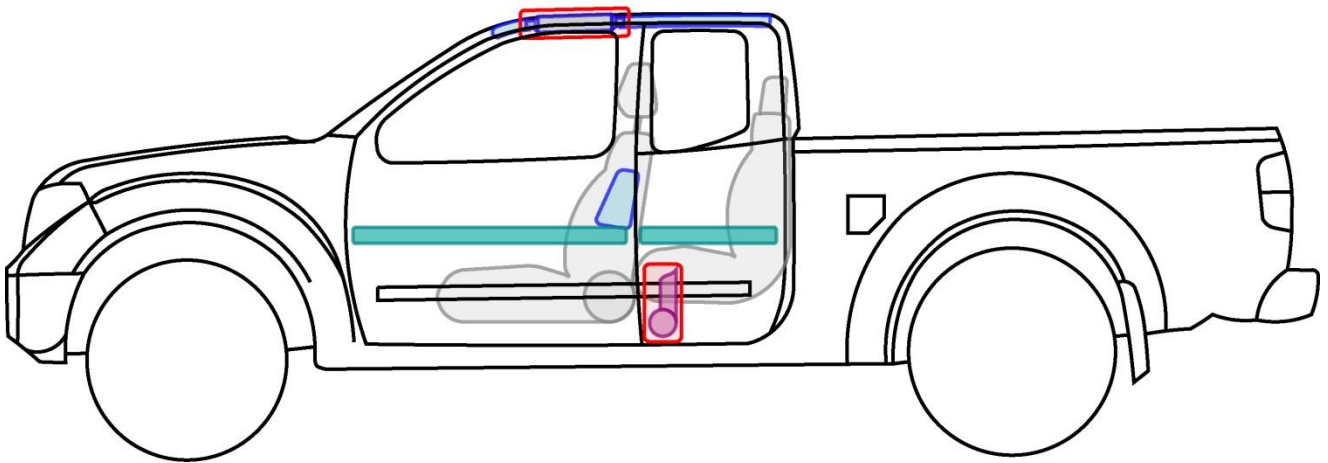
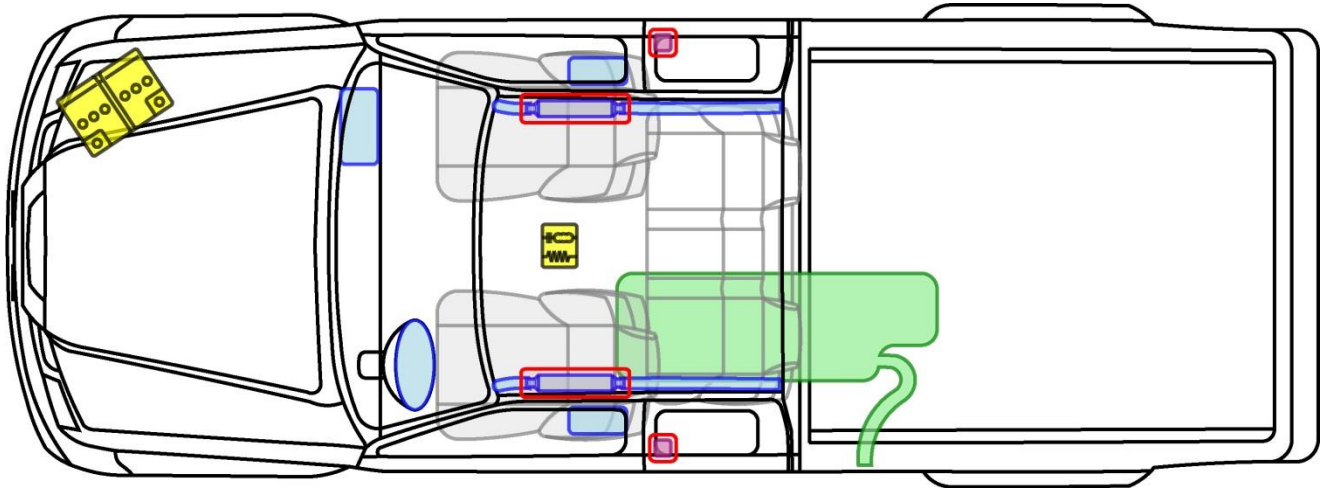

# NAVARA King Cab

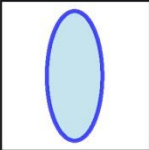
Typ: D40, 2005-

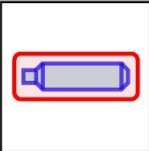
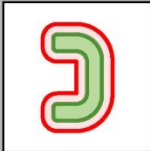
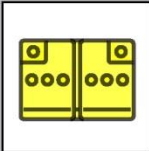

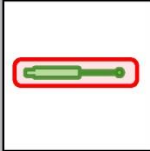
## Legende

	Airbag		Karosserie- verstärkung		Steuergerät
	Gas- generator		Überroll- schutz		Batterie
	Gurt- straffer		Gasdruck- dämpfer		Kraftstoff- tank











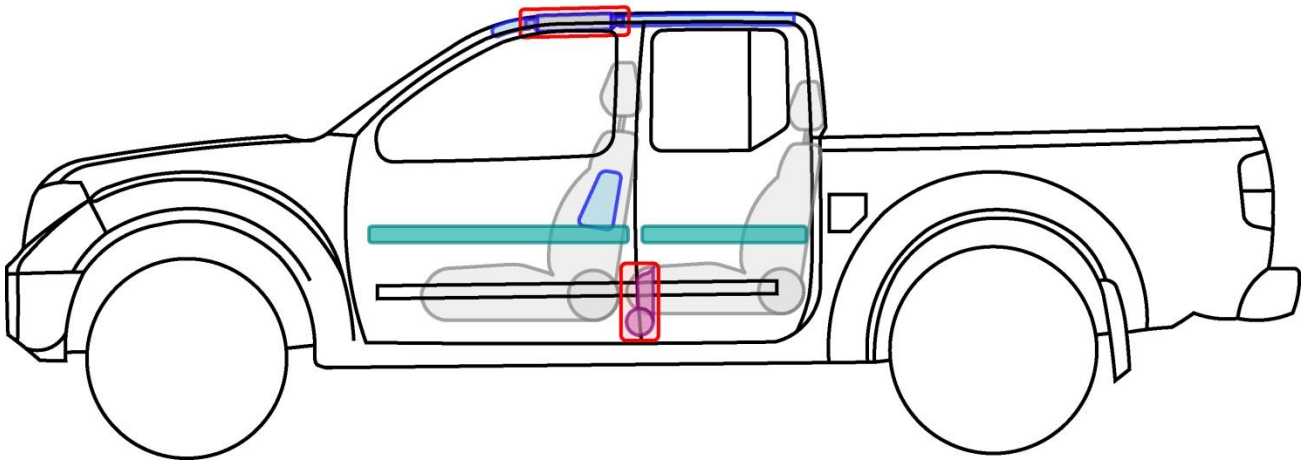
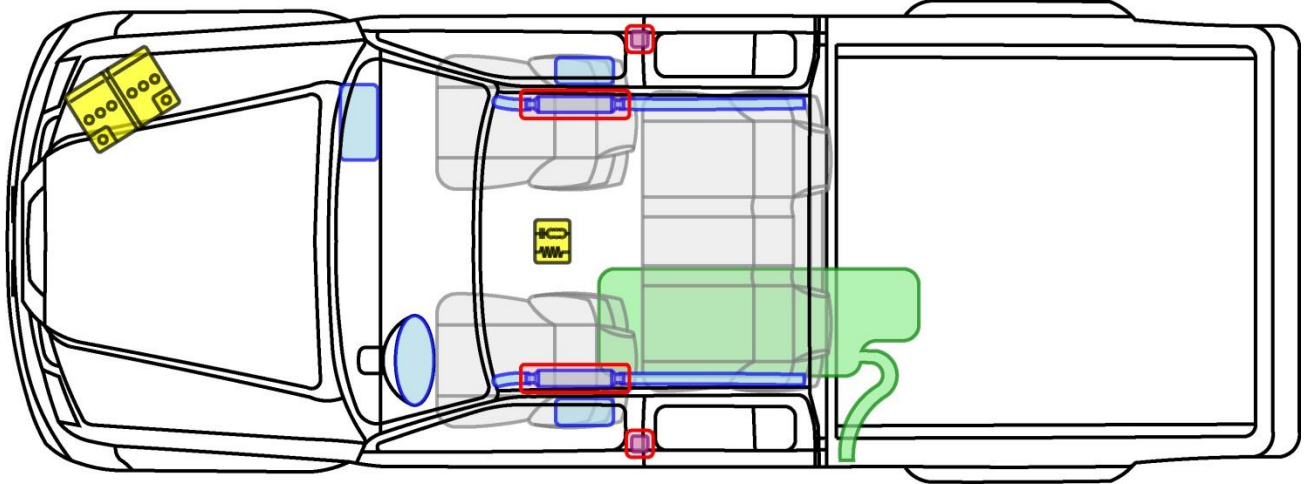

# NAVARA Crew Cab

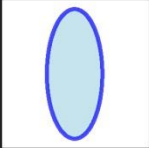
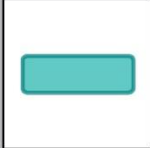
Typ: D40, 2005-

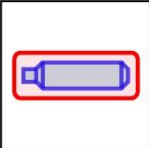

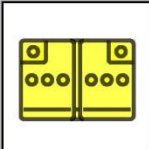
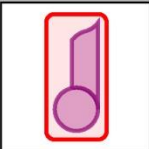
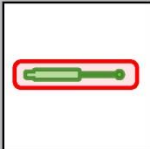
## Legende

	Airbag		Karosserie- verstärkung		Steuergerät
	Gas- generator		Überroll- schutz		Batterie
	Gurt- straffer		Gasdruck- dämpfer		Kraftstoff- tank

NAVARA





# NOTE

Typ: E11, 2006-2013

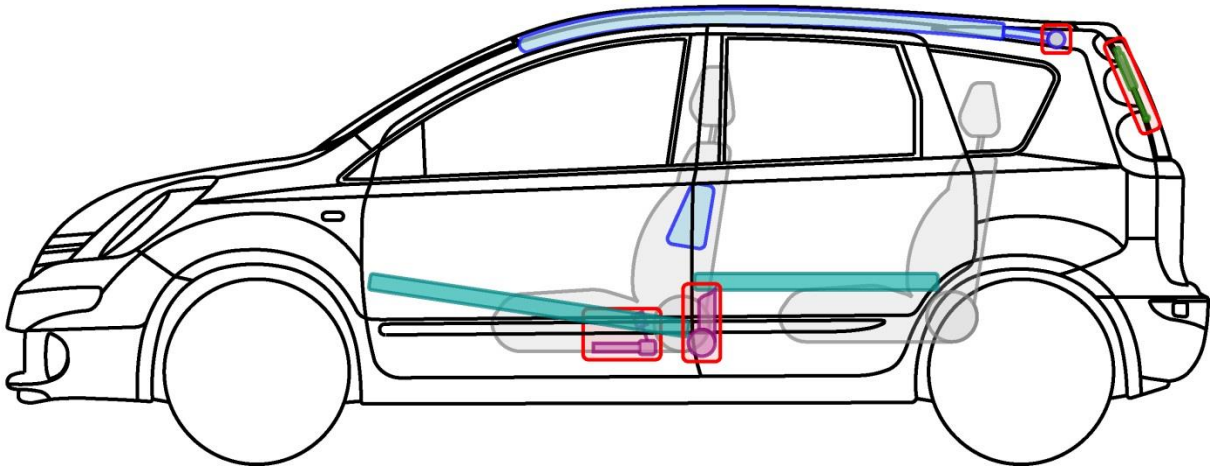
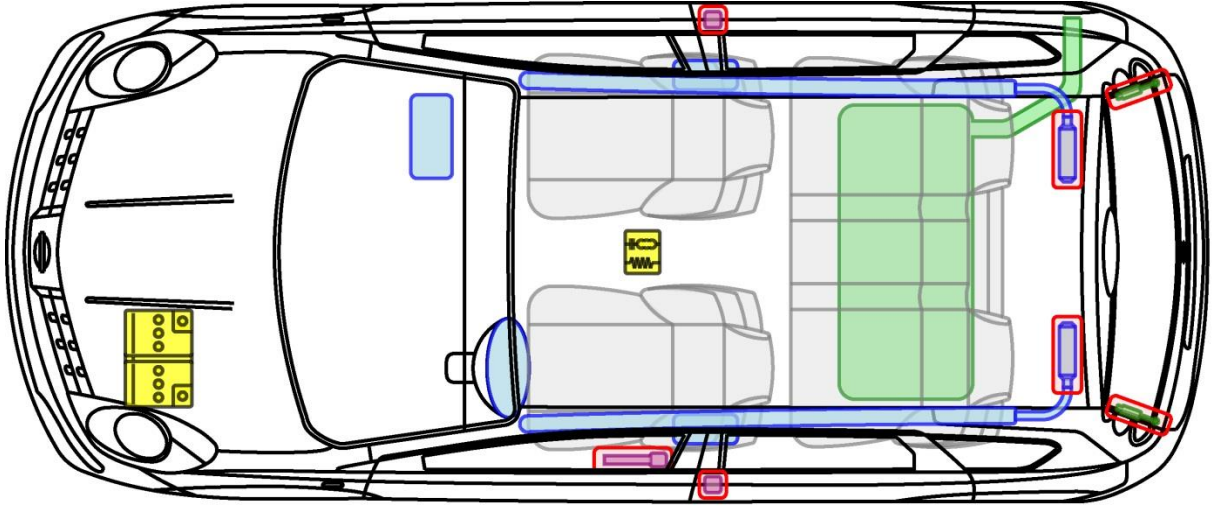

## Legende

	Airbag		Karosserie- verstärkung		Steuergerät
	Gas- generator		Überroll- schutz		Batterie
	Gurt- straffer		Gasdruck- dämpfer		Kraftstoff- tank

NOTE







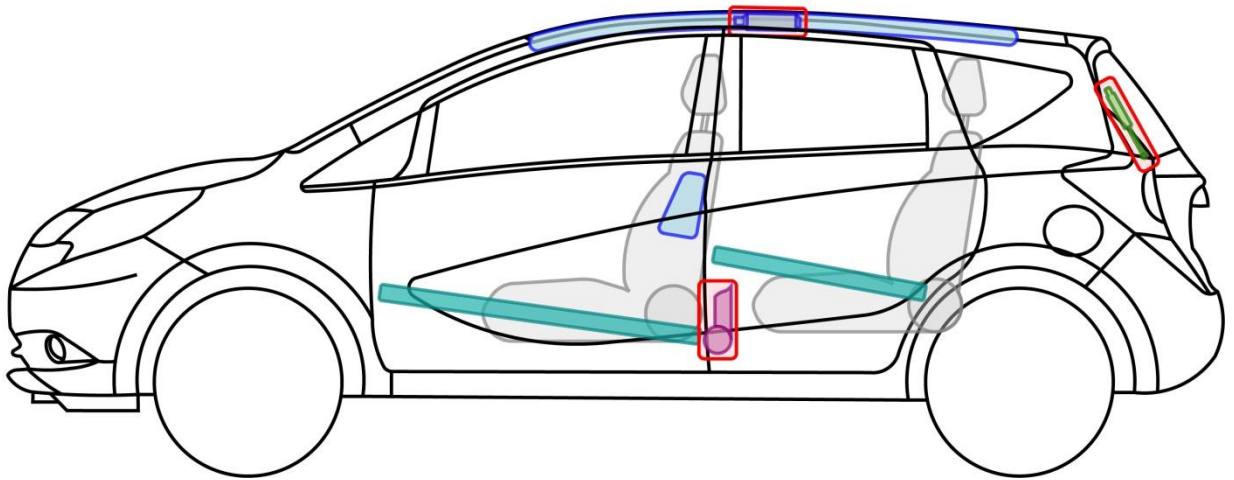
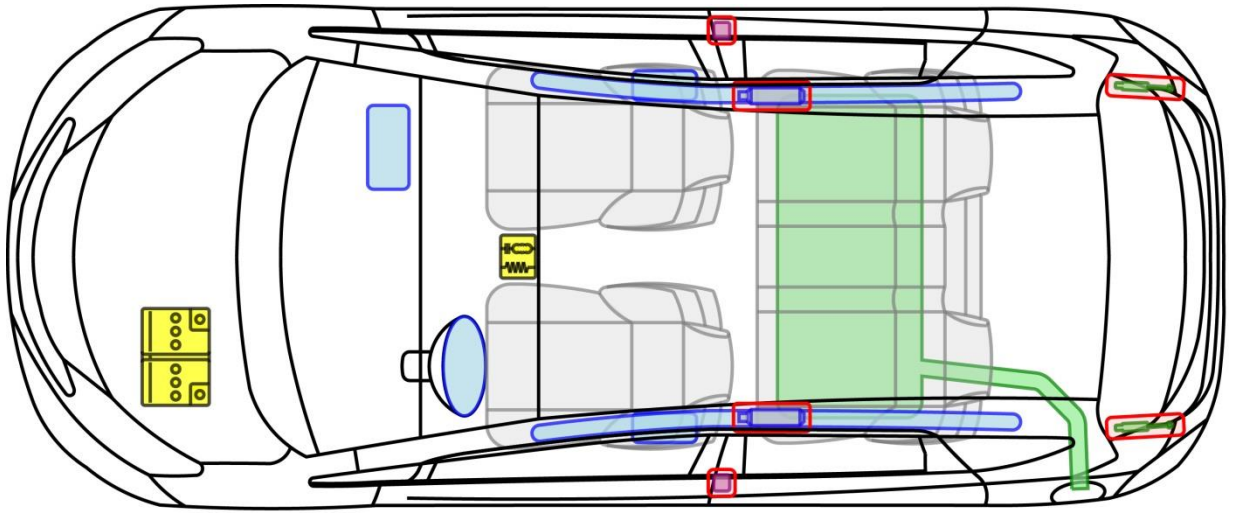

# NOTE

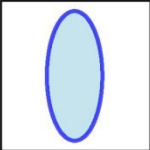
Typ: E12, 2013-

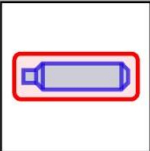

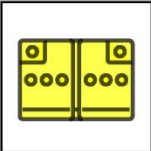
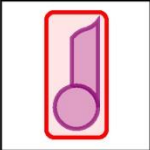
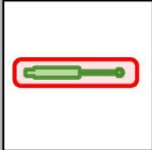
## Legende

	Airbag		Karosserie- verstärkung		Steuergerät
	Gas- generator		Überroll- schutz		Batterie
	Gurt- straffer		Gasdruck- dämpfer		Kraftstoff- tank

NOTE







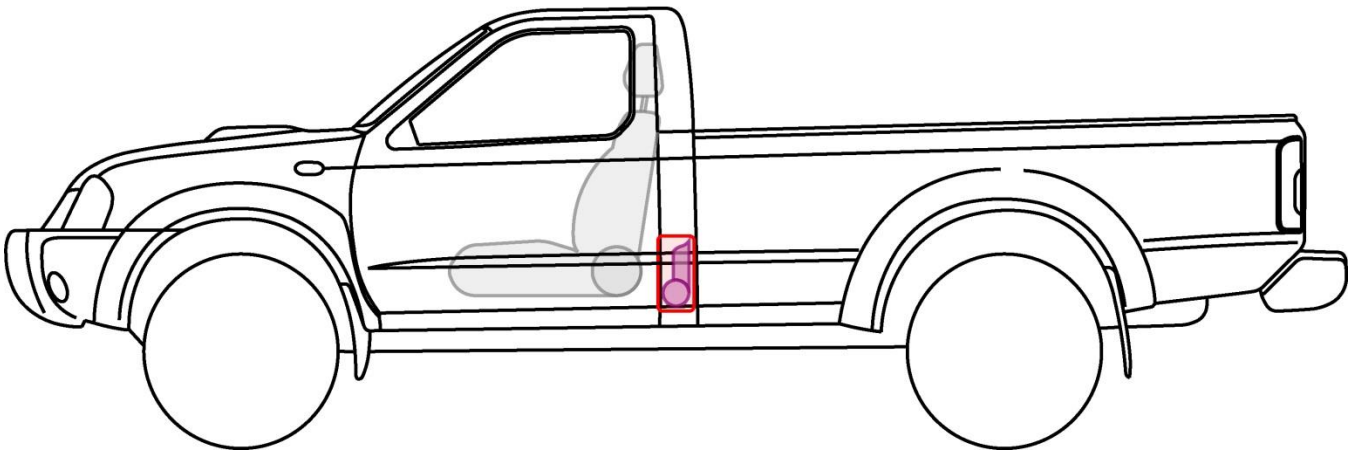
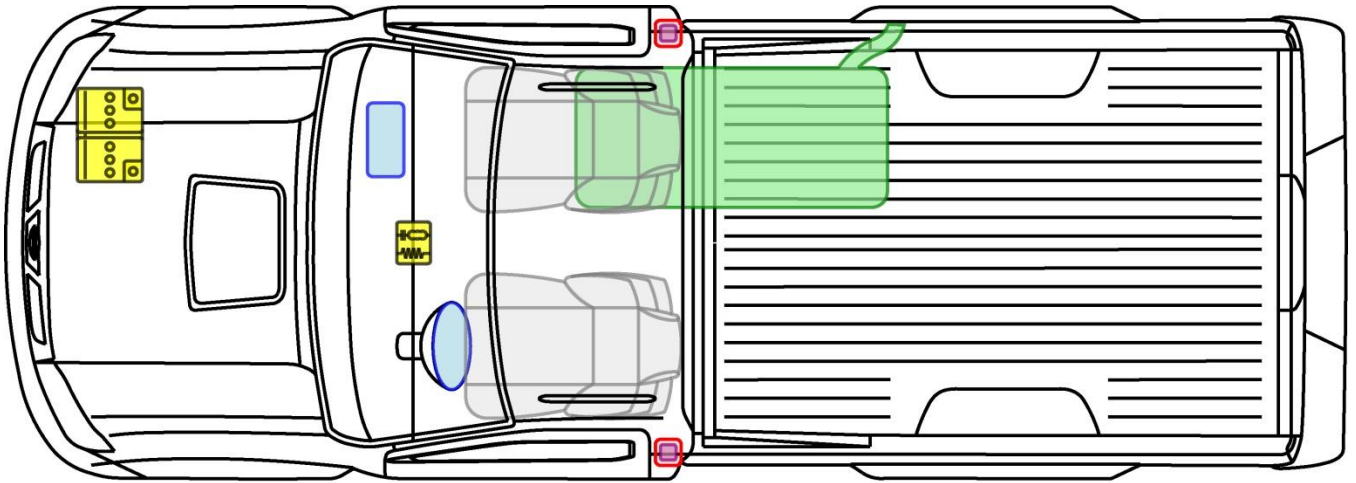

# NP300 Single Cab

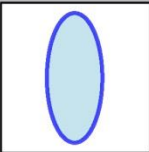
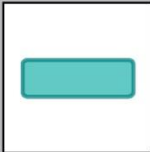
Typ: D22, 2008-2011

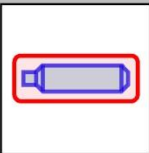

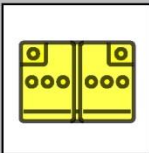
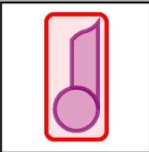
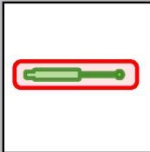
## Legende

	Airbag		Karosserie- verstärkung		Steuergerät
	Gas- generator		Überroll- schutz		Batterie
	Gurt- straffer		Gasdruck- dämpfer		Kraftstoff- tank

NP300







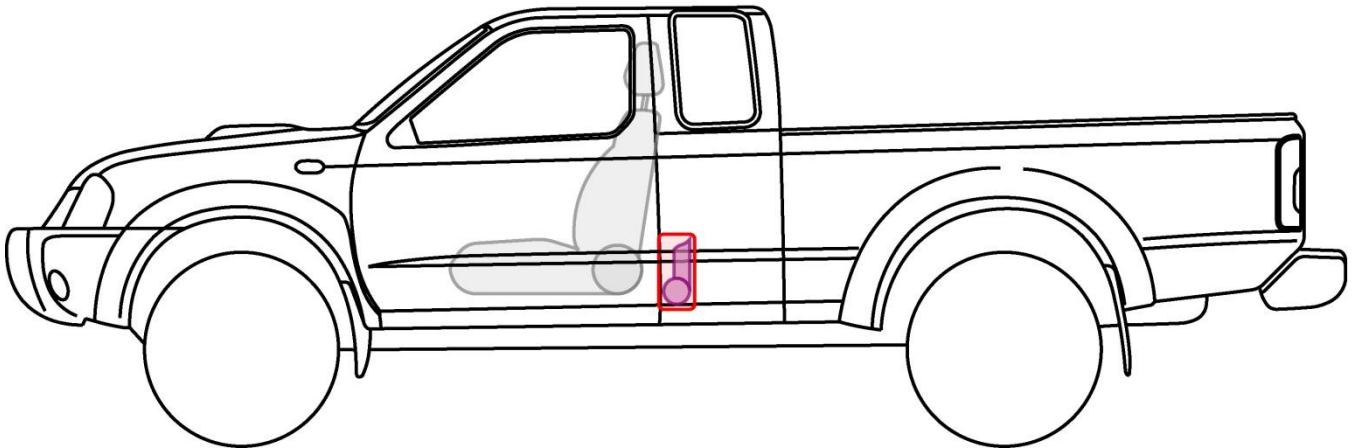
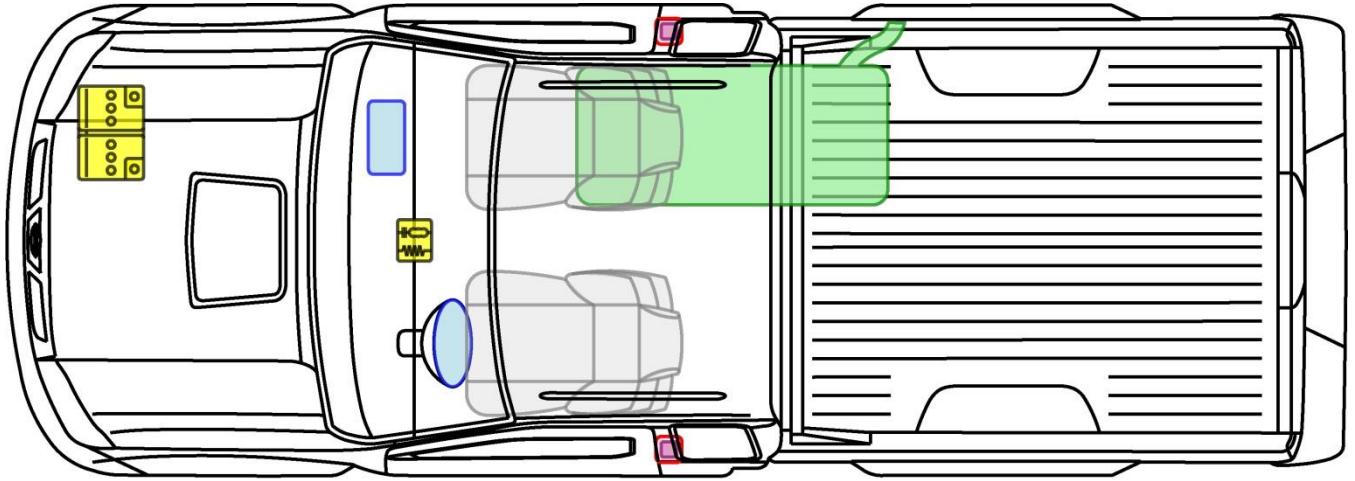

# NP300 King Cab

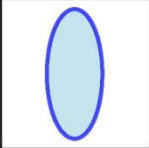
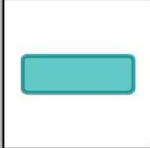
Typ: D22, 2008-2011

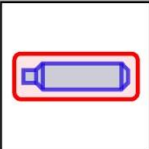

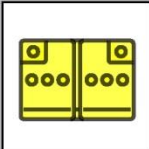
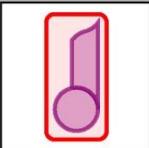
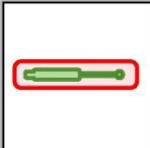
## Legende

	Airbag		Karosserie- verstärkung		Steuergerät
	Gas- generator		Überroll- schutz		Batterie
	Gurt- straffer		Gasdruck- dämpfer		Kraftstoff- tank

NP300









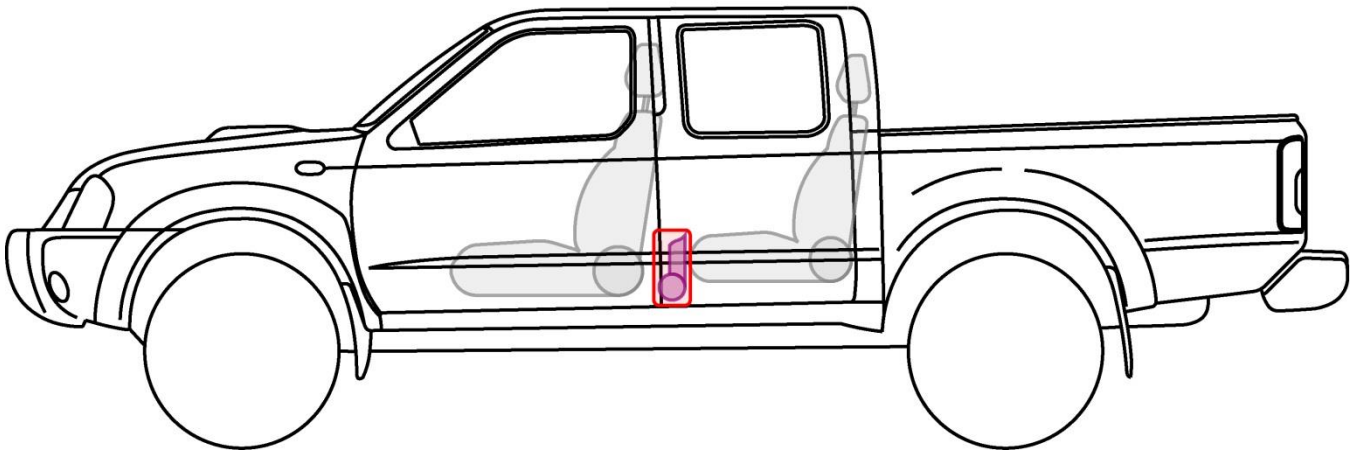
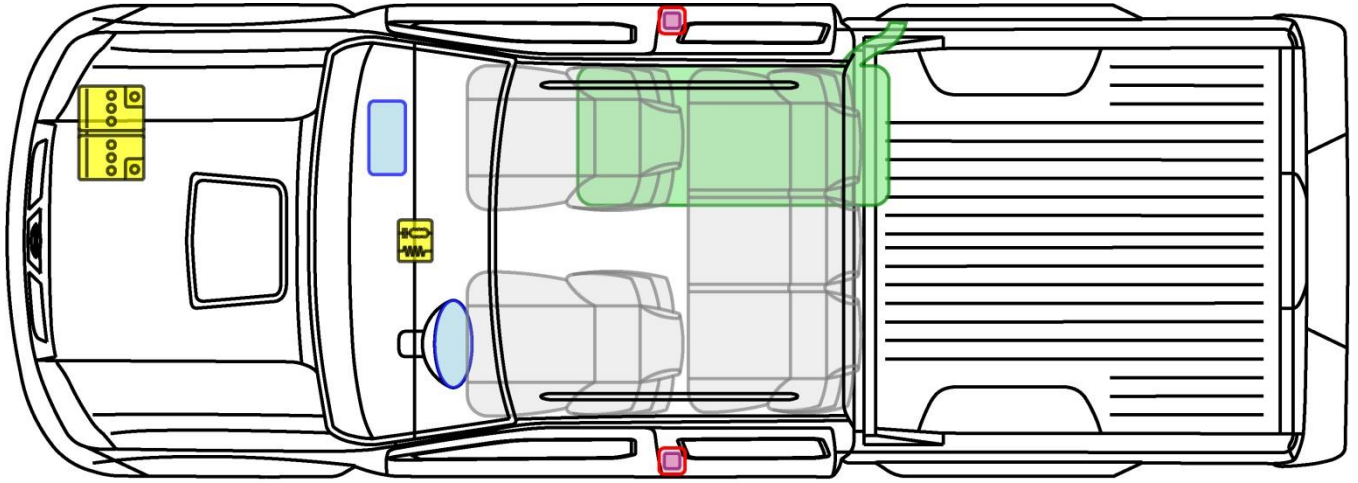

# NP300 Double Cab

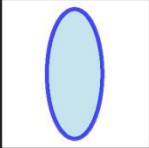
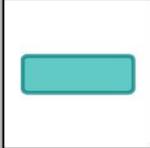
Typ: D22, 2008-2011

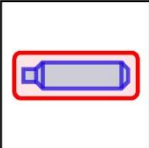

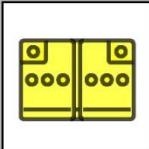
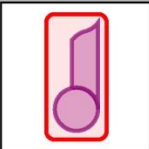
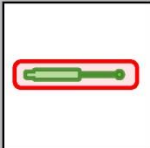
## Legende

	Airbag		Karosserie- verstärkung		Steuergerät
	Gas- generator		Überroll- schutz		Batterie
	Gurt- straffer		Gasdruck- dämpfer		Kraftstoff- tank

NP300



# NT400 CABSTAR

Typ: F24, 2006-

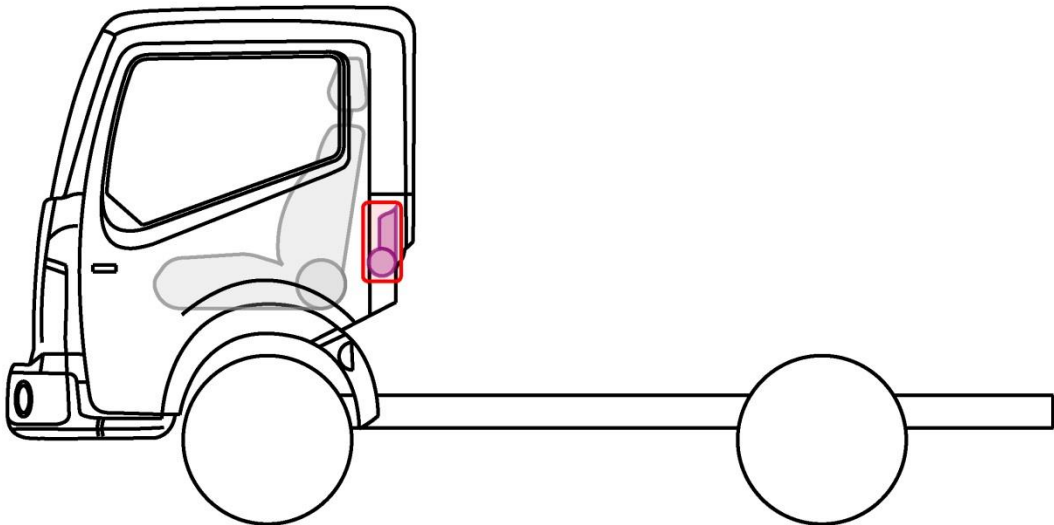
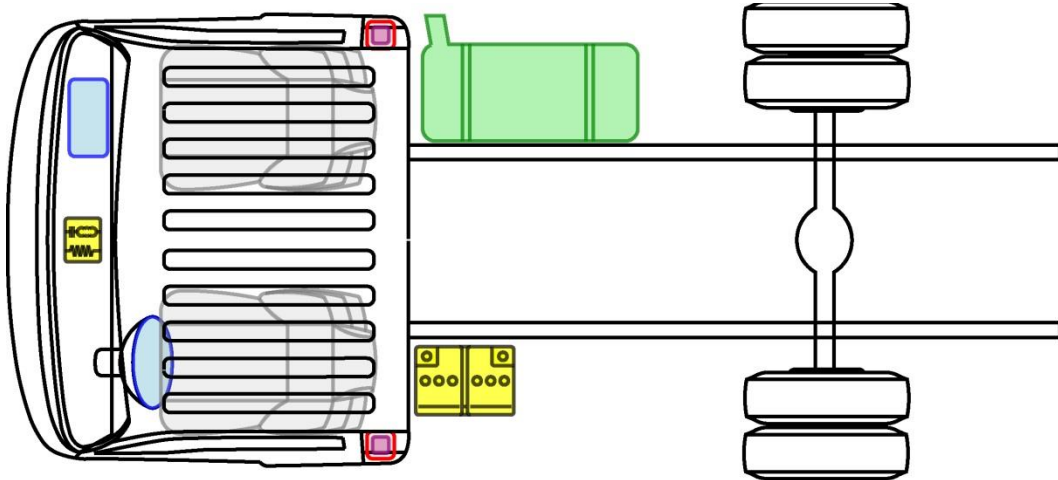

## Legende

	Airbag		Karosserie- verstärkung		Steuergerät
	Gas- generator		Überroll- schutz		Batterie
	Gurt- straffer		Gasdruck- dämpfer		Kraftstoff- tank

NT400



# NV200

Typ: M20, 2009-

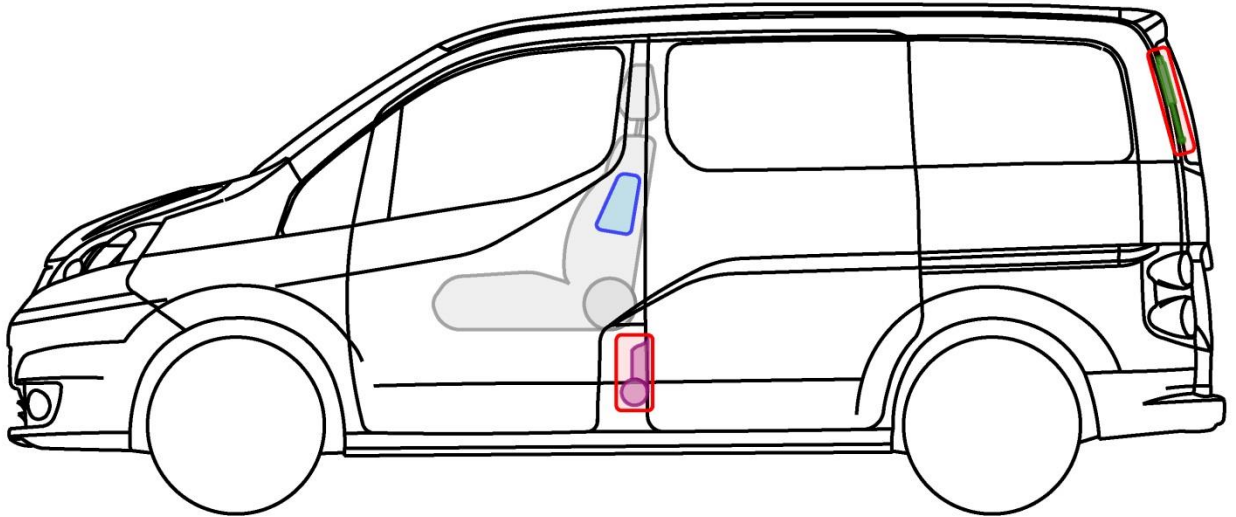
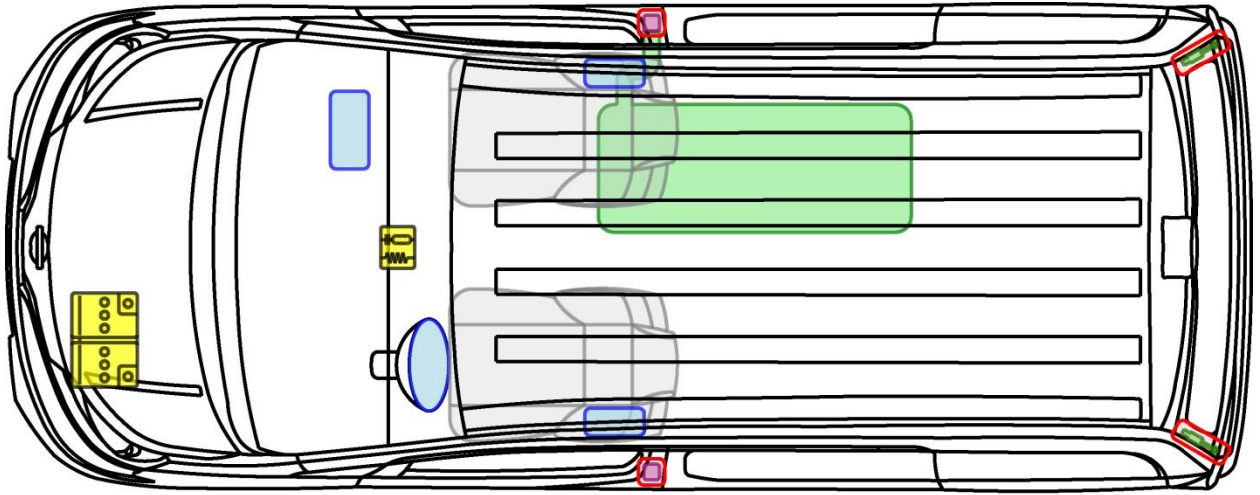

## Legende

	Airbag		Karosserie- verstärkung		Steuergerät
	Gas- generator		Überroll- schutz		Batterie
	Gurt- straffer		Gasdruck- dämpfer		Kraftstoff- tank

NV200



# NV400

Typ: M9, 2011-

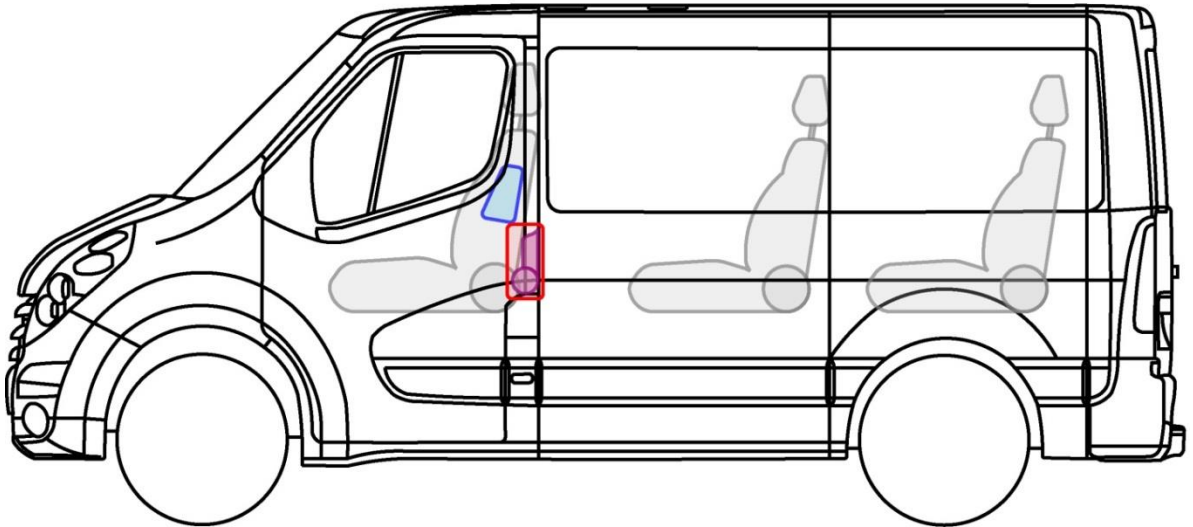
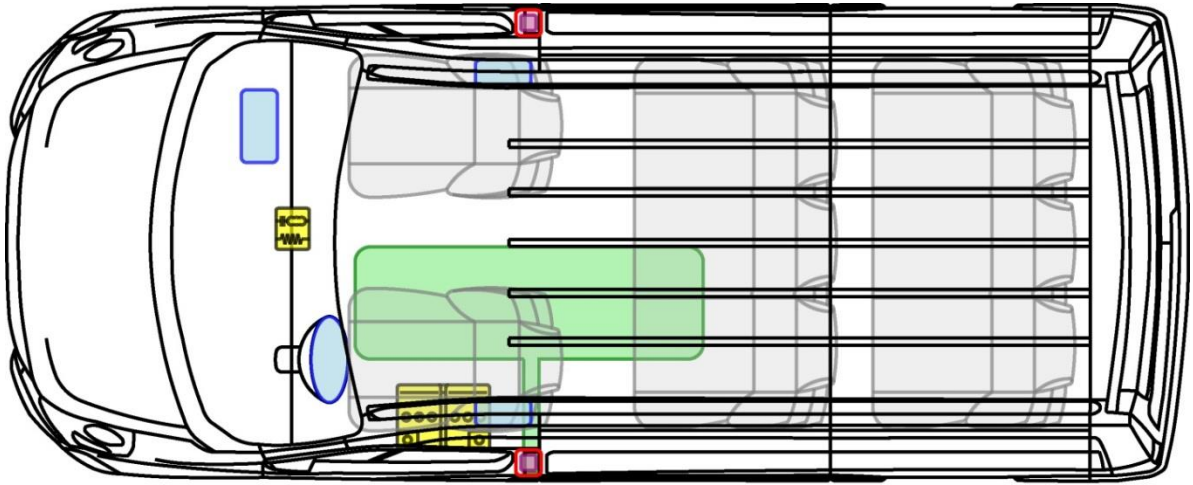

## Legende

	Airbag		Karosserie- verstärkung		Steuergerät
	Gas- generator		Überroll- schutz		Batterie
	Gurt- straffer		Gasdruck- dämpfer		Kraftstoff- tank

NV400









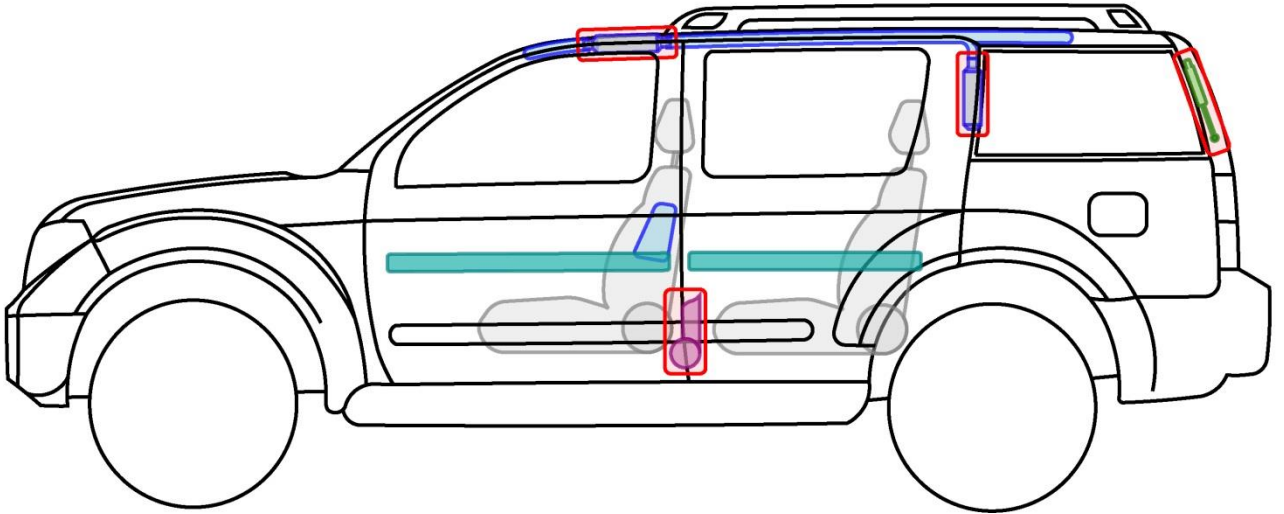
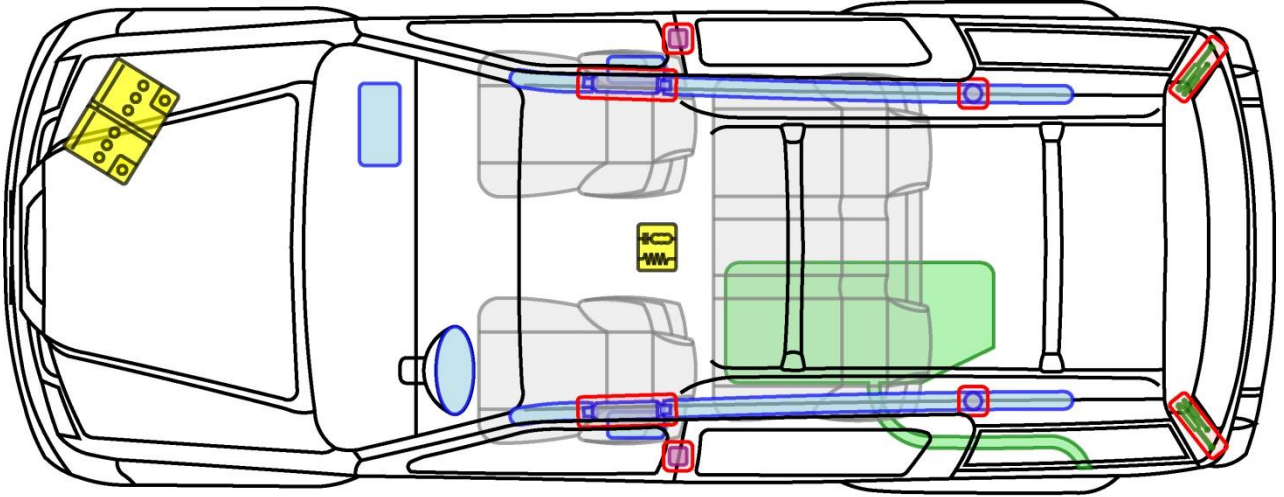

# PATHFINDER

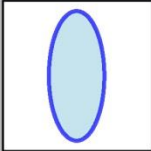
Typ: R51, 2005-

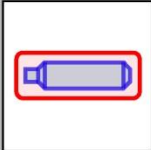

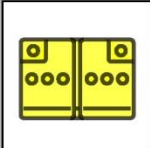
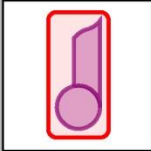
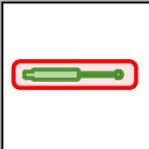
## Legende

	Airbag		Karosserie- verstärkung		Steuergerät
	Gas- generator		Überroll- schutz		Batterie
	Gurt- straffer		Gasdruck- dämpfer		Kraftstoff- tank

PATHFINDER







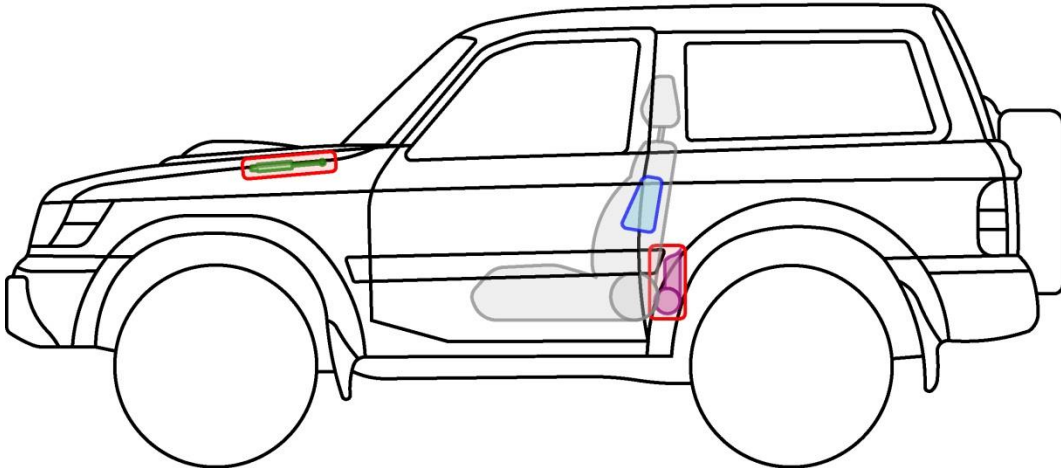
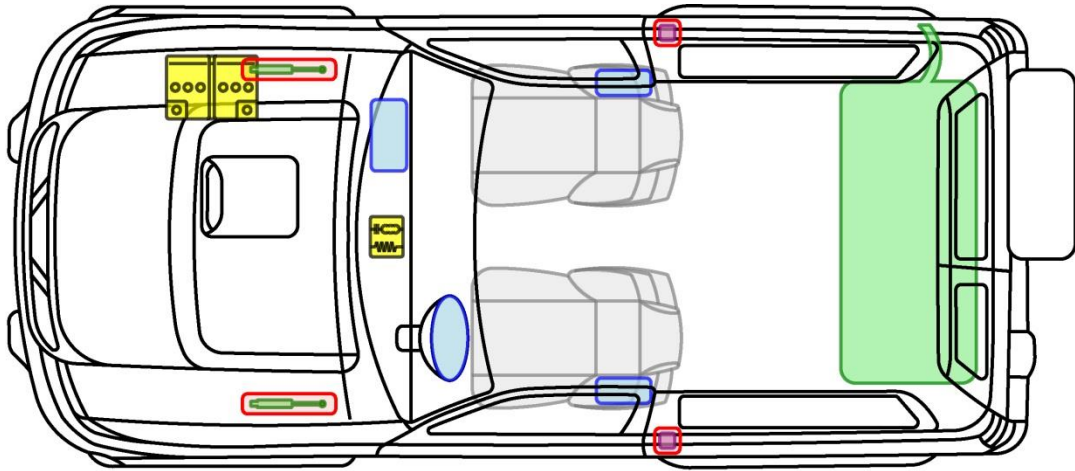

# PATROL 3-Türer

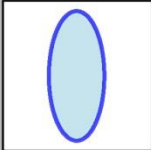
Typ: Y61, 2000-2009

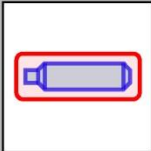

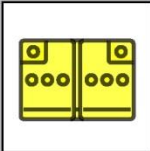
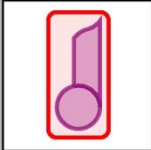
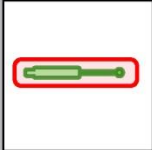
## Legende

	Airbag		Karosserie- verstärkung		Steuergerät
	Gas- generator		Überroll- schutz		Batterie
	Gurt- straffer		Gasdruck- dämpfer		Kraftstoff- tank

PATROL







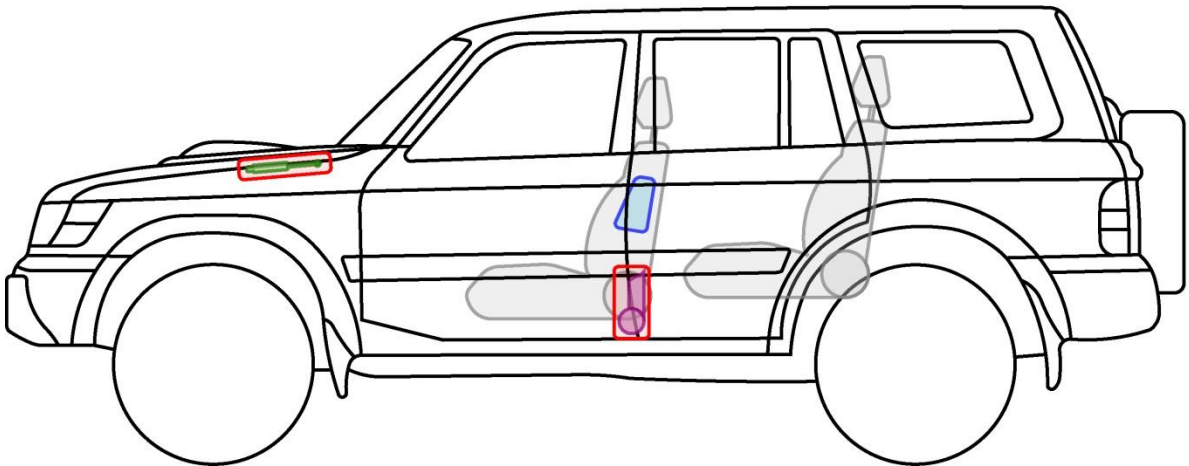
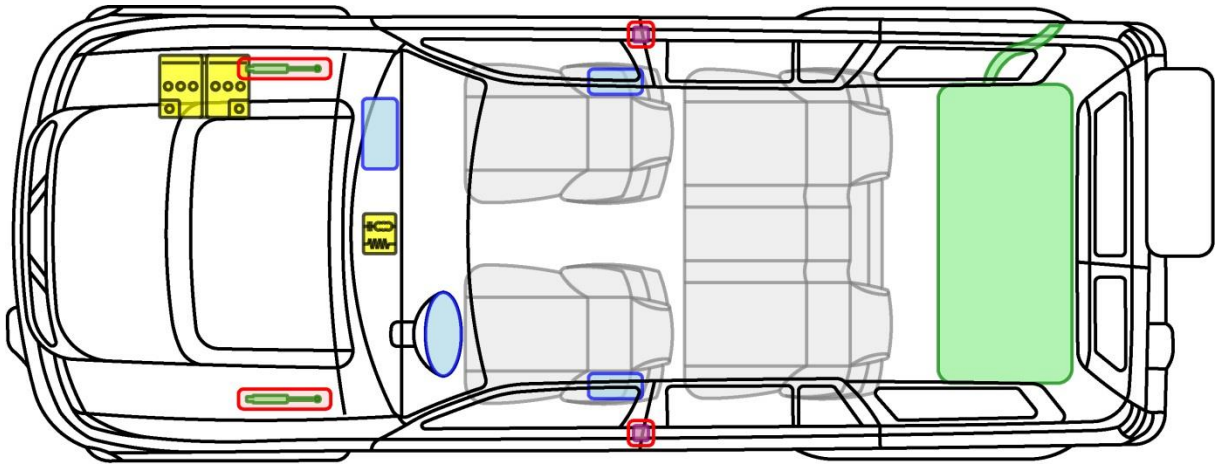

# PATROL 5-Türer

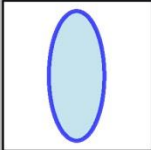
Typ: Y61, 2000-2009

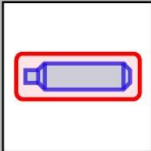

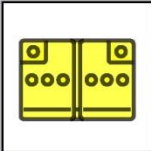
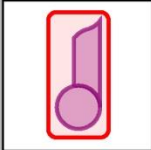
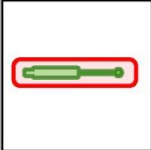
## Legende

	Airbag		Karosserie- verstärkung		Steuergerät
	Gas- generator		Überroll- schutz		Batterie
	Gurt- straffer		Gasdruck- dämpfer		Kraftstoff- tank

PATROL







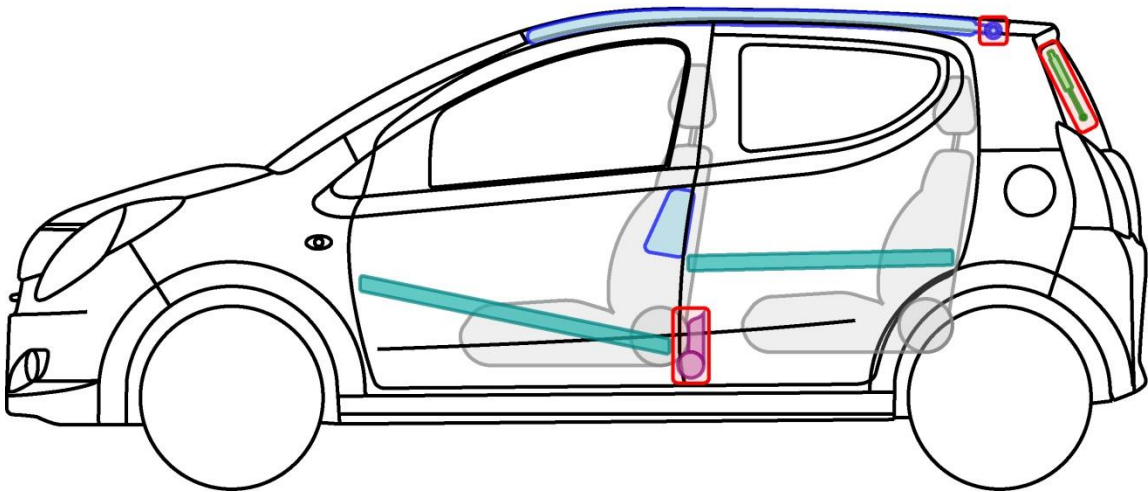
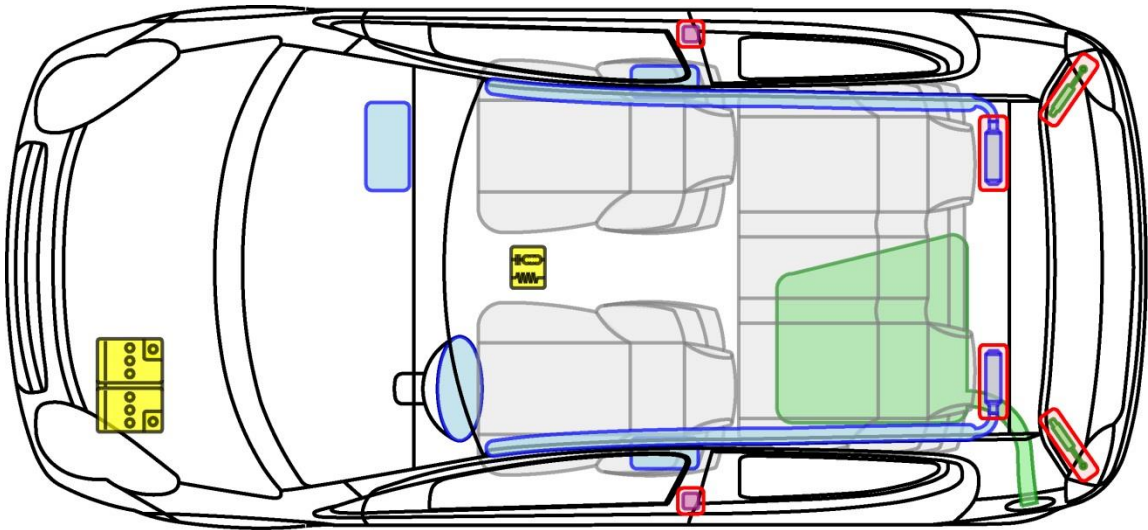

# PIXO

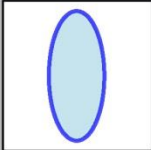
Typ: UA0, 2009-2013

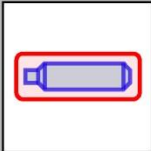

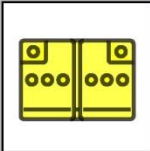
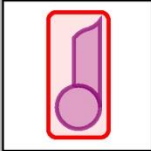
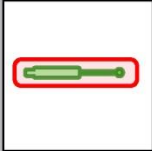
## Legende

	Airbag		Karosserie- verstärkung		Steuergerät
	Gas- generator		Überroll- schutz		Batterie
	Gurt- straffer		Gasdruck- dämpfer		Kraftstoff- tank











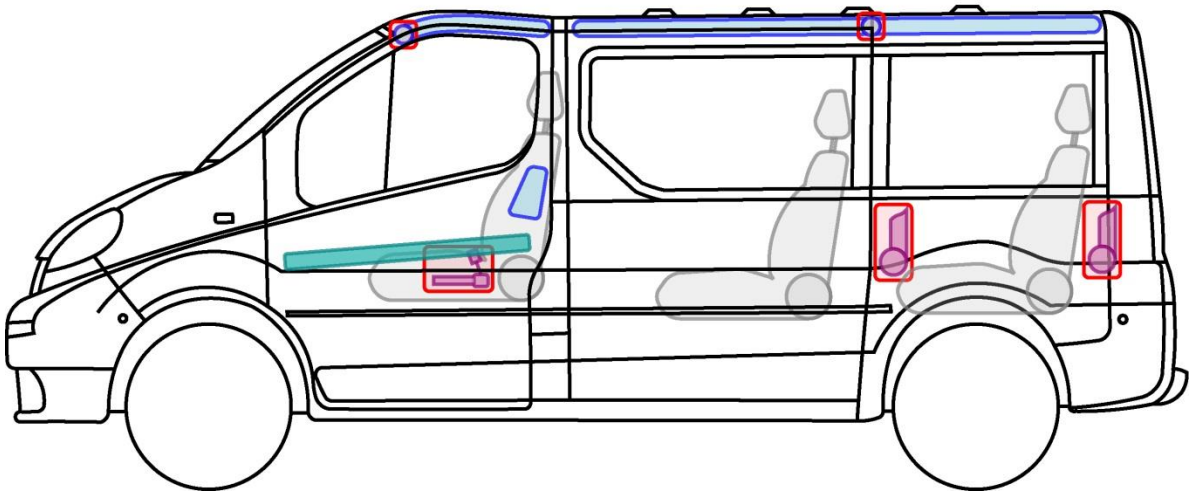
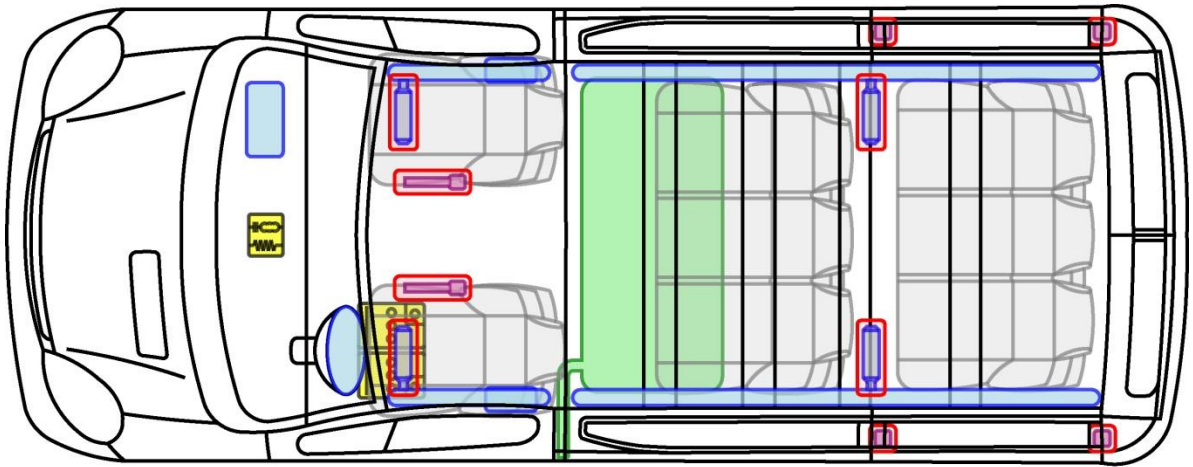

# PRIMASTAR

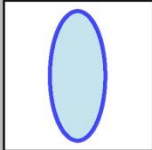
Typ: X83, 2003-

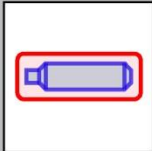
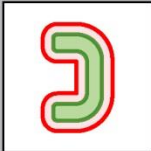
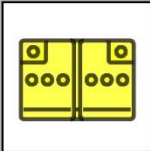

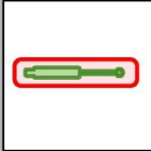
## Legende

	Airbag		Karosserie- verstärkung		Steuergerät
	Gas- generator		Überroll- schutz		Batterie
	Gurt- straffer		Gasdruck- dämpfer		Kraftstoff- tank

**PRIMASTAR**







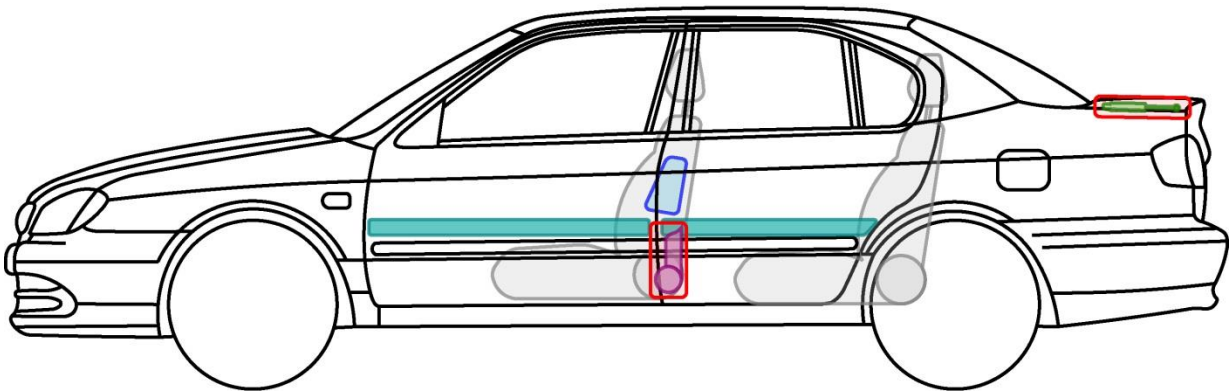
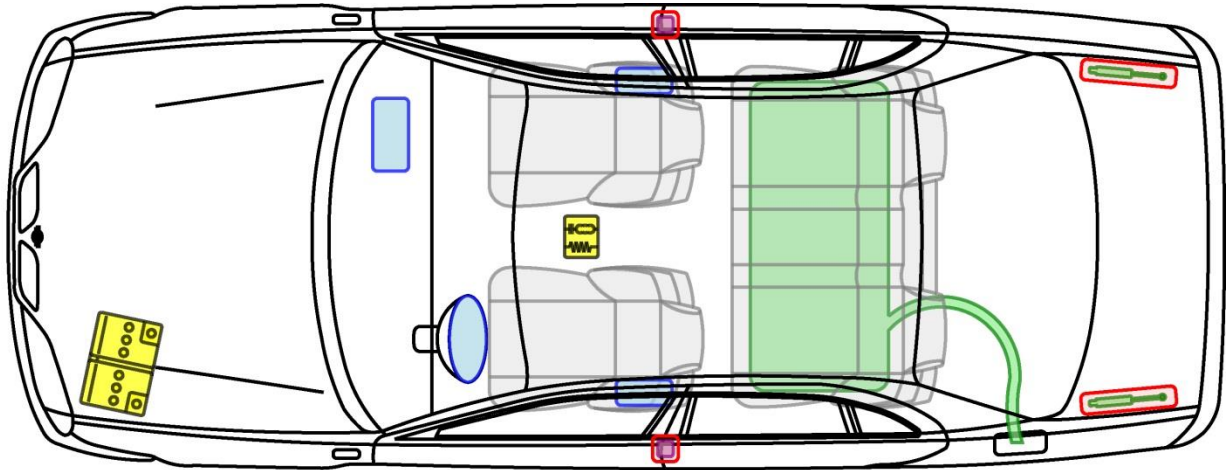

# PRIMERA 4-Türer

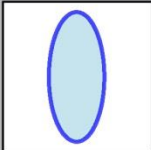
Typ: P11, 1994-2002

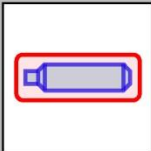

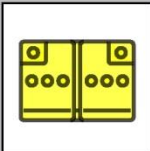
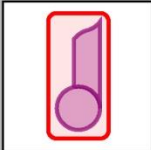
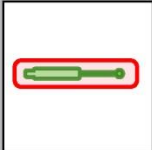
## Legende

	Airbag		Karosserie- verstärkung		Steuergerät
	Gas- generator		Überroll- schutz		Batterie
	Gurt- straffer		Gasdruck- dämpfer		Kraftstoff- tank

PRIMERA



# PRIMERA 5-Türer

Typ: P11, 1994-2002

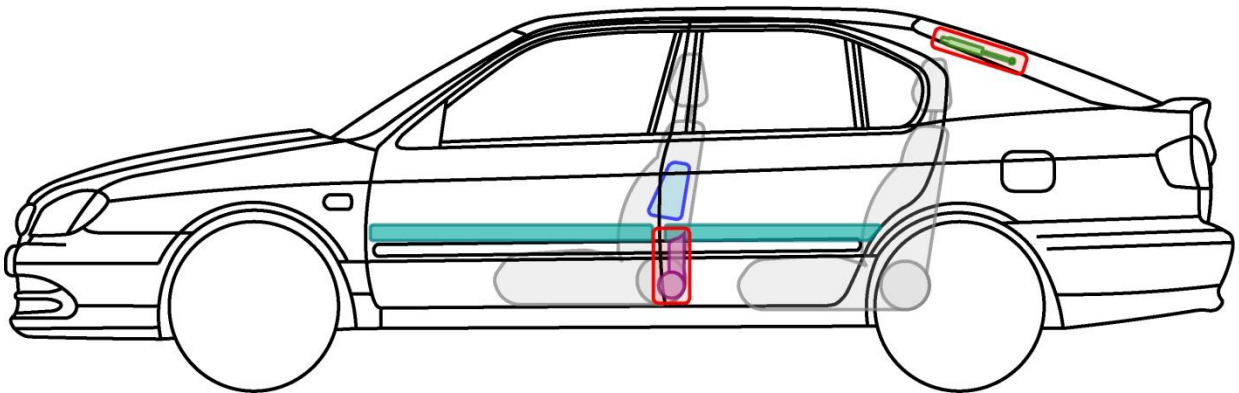
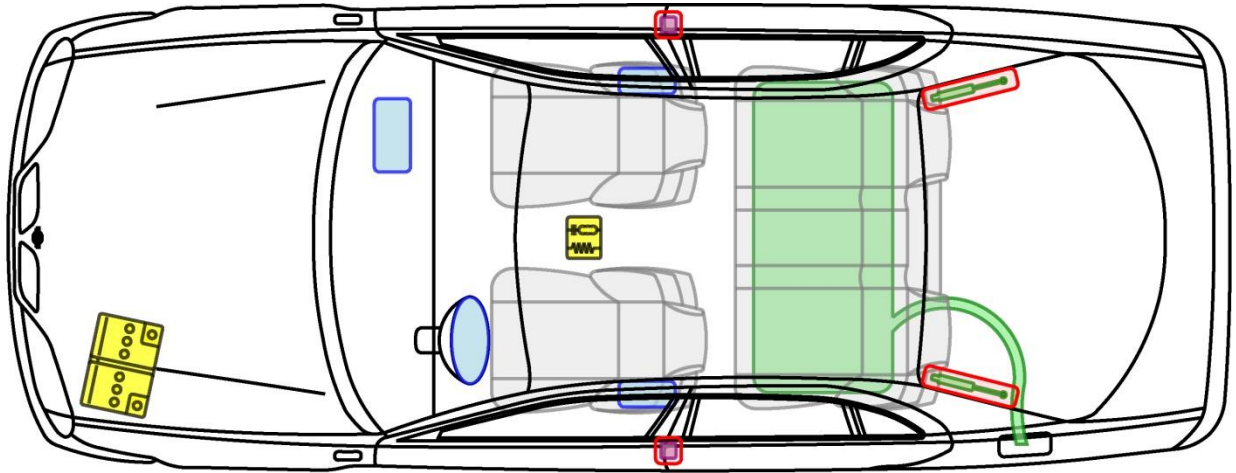

## Legende

	Airbag		Karosserie- verstärkung		Steuergerät
	Gas- generator		Überroll- schutz		Batterie
	Gurt- straffer		Gasdruck- dämpfer		Kraftstoff- tank









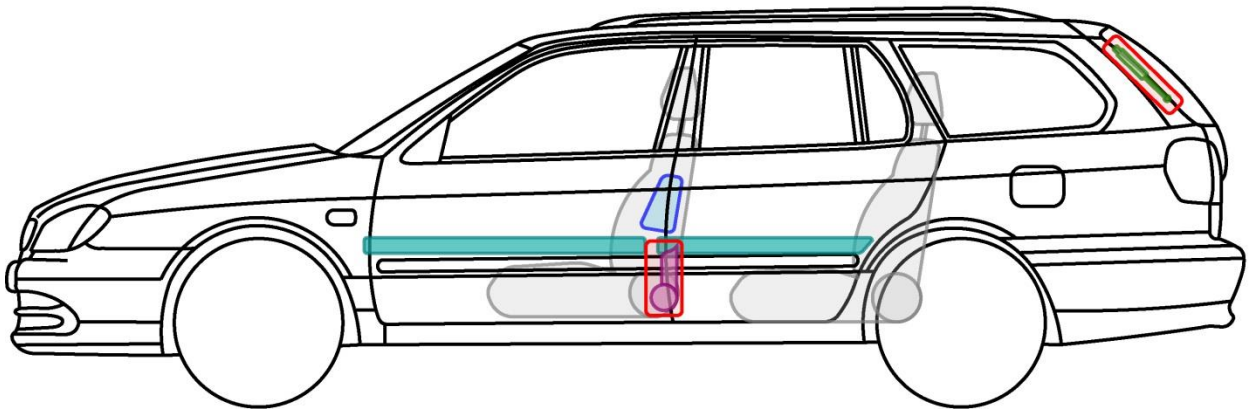
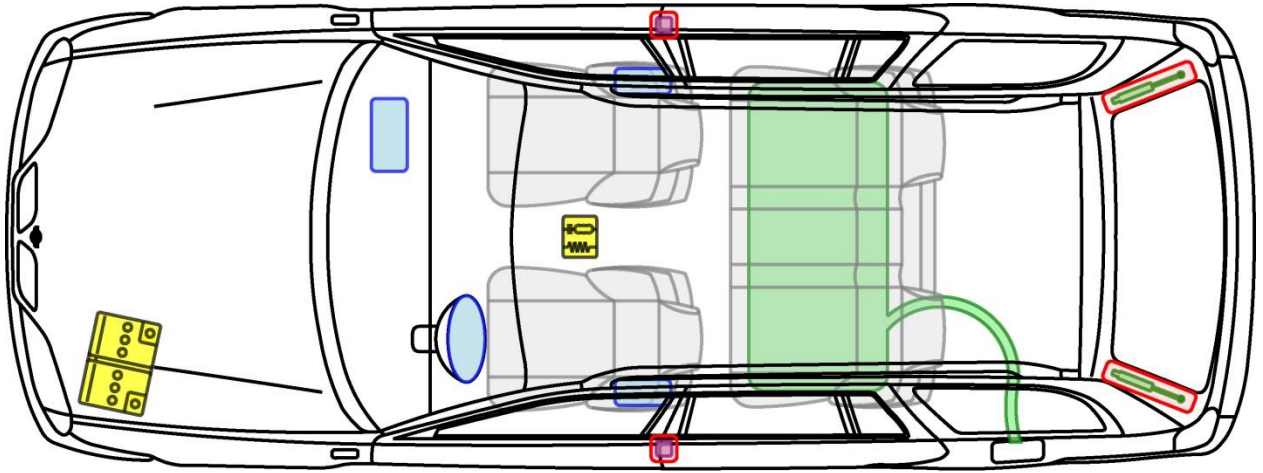

# PRIMERA Kombi

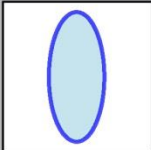
Typ: P11, 1994-2002

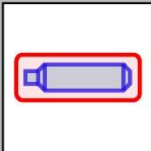

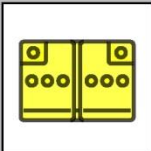
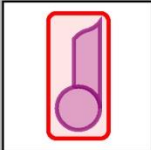
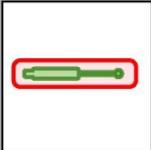
## Legende

	Airbag		Karosserie- verstärkung		Steuergerät
	Gas- generator		Überroll- schutz		Batterie
	Gurt- straffer		Gasdruck- dämpfer		Kraftstoff- tank

PRIMERA









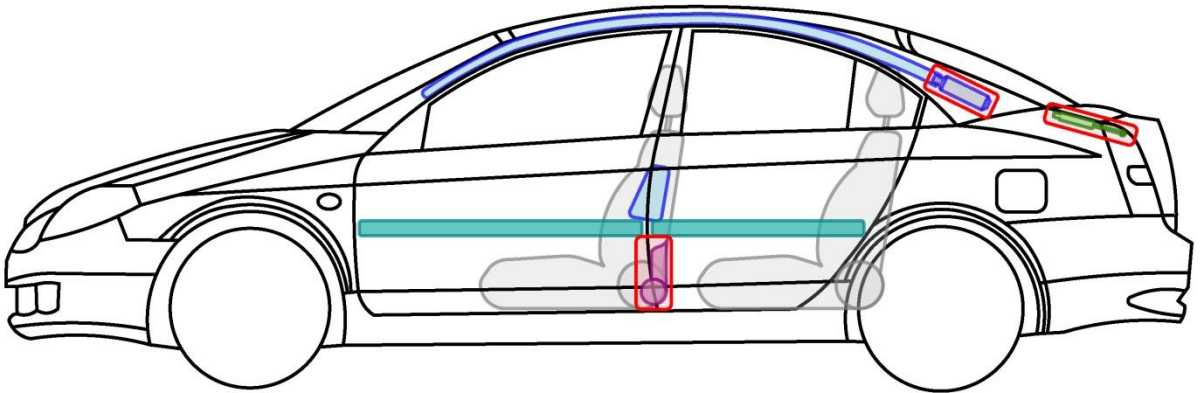
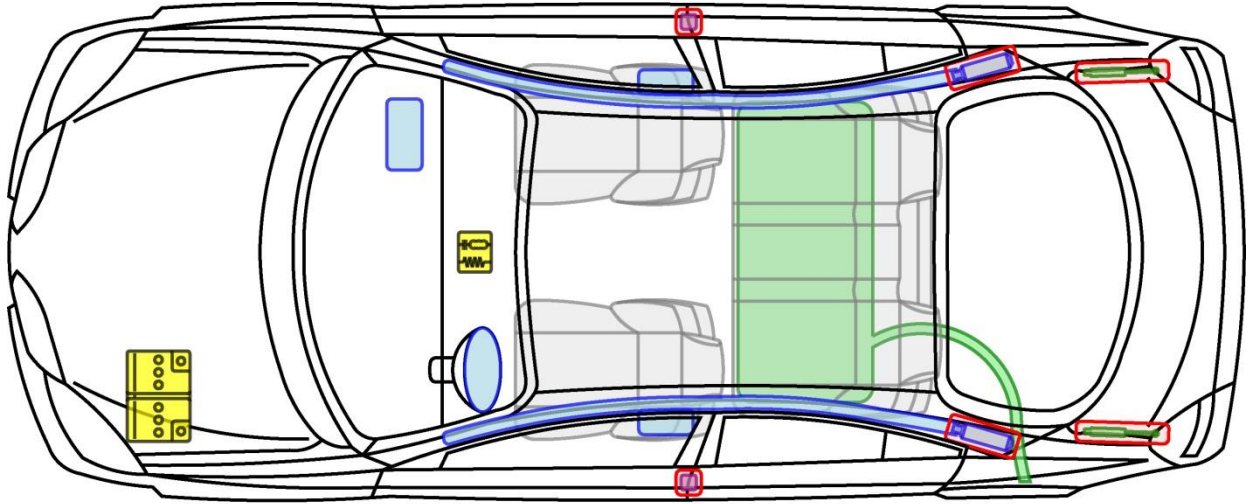

# PRIMERA 4-Türer

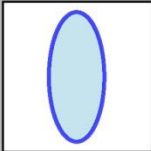
Typ: P12, 2002-2008

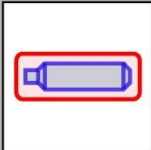

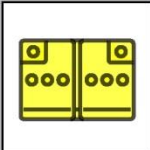
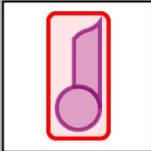
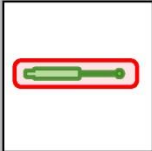
## Legende

	Airbag		Karosserie- verstärkung		Steuergerät
	Gas- generator		Überroll- schutz		Batterie
	Gurt- straffer		Gasdruck- dämpfer		Kraftstoff- tank

PRIMERA







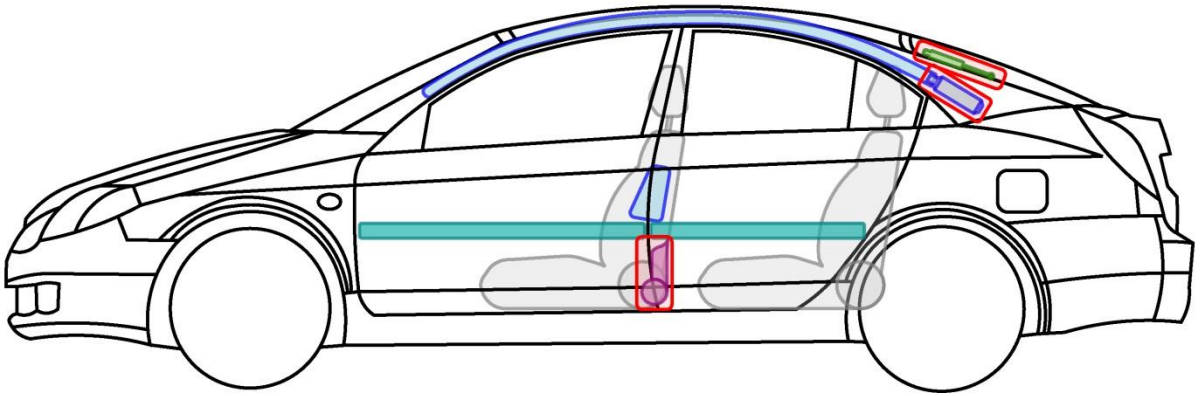
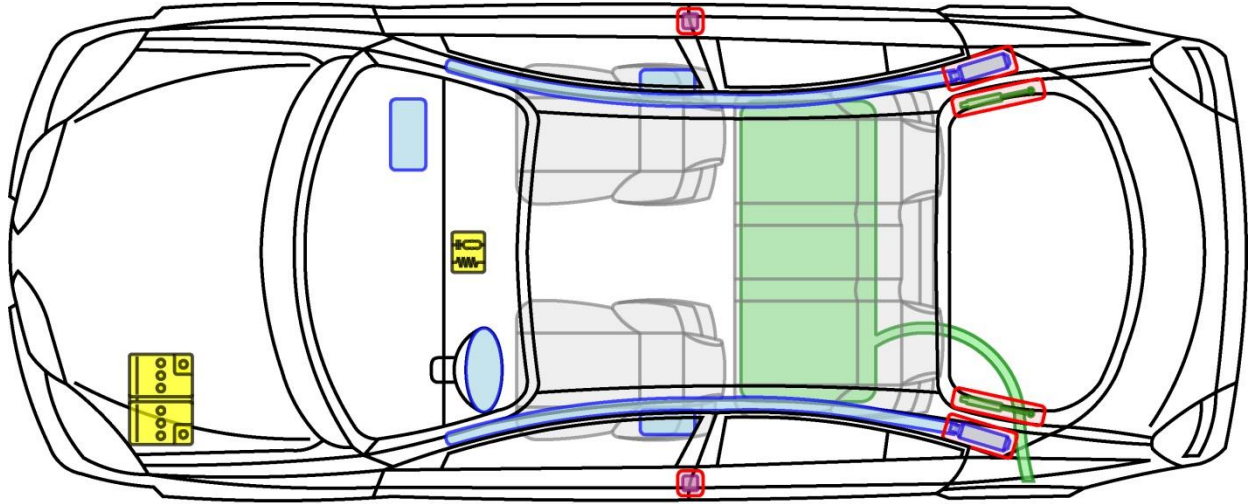

# PRIMERA 5-Türer

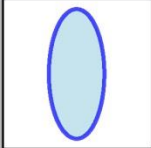
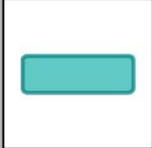
Typ: P12, 2002-2008

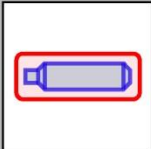

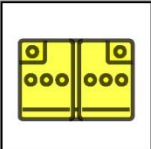
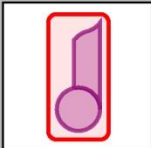
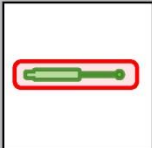
## Legende

	Airbag		Karosserie- verstärkung		Steuergerät
	Gas- generator		Überroll- schutz		Batterie
	Gurt- straffer		Gasdruck- dämpfer		Kraftstoff- tank

PRIMERA







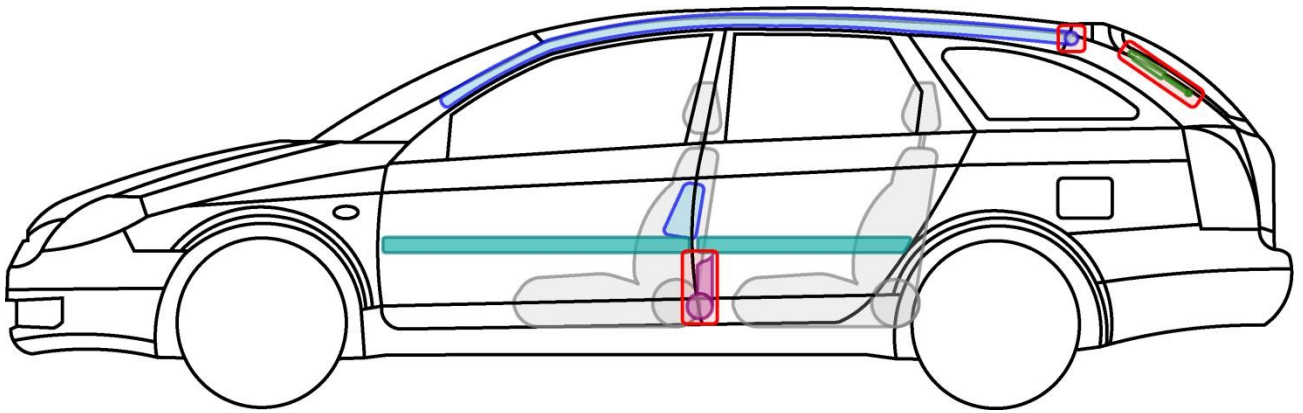
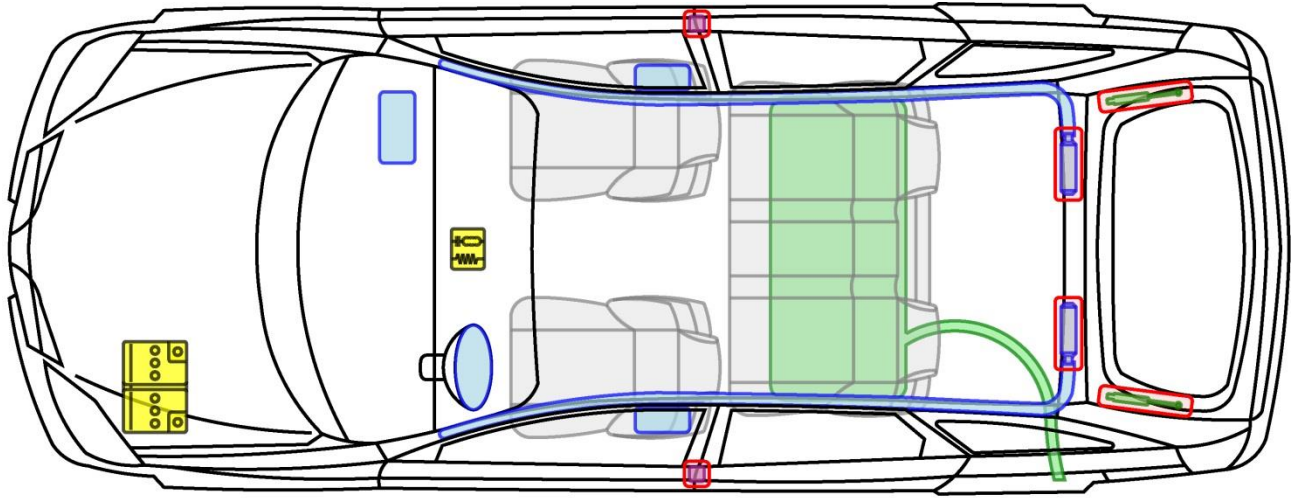

# PRIMERA Kombi

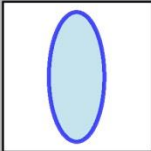
Typ: P12, 2002-2008

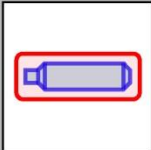

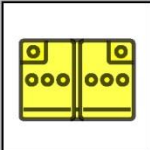
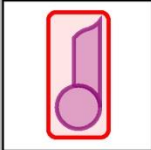
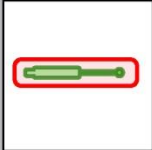
## Legende

	Airbag		Karosserie- verstärkung		Steuergerät
	Gas- generator		Überroll- schutz		Batterie
	Gurt- straffer		Gasdruck- dämpfer		Kraftstoff- tank

PRIMERA





# PULSAR

Typ: C13, 2014-

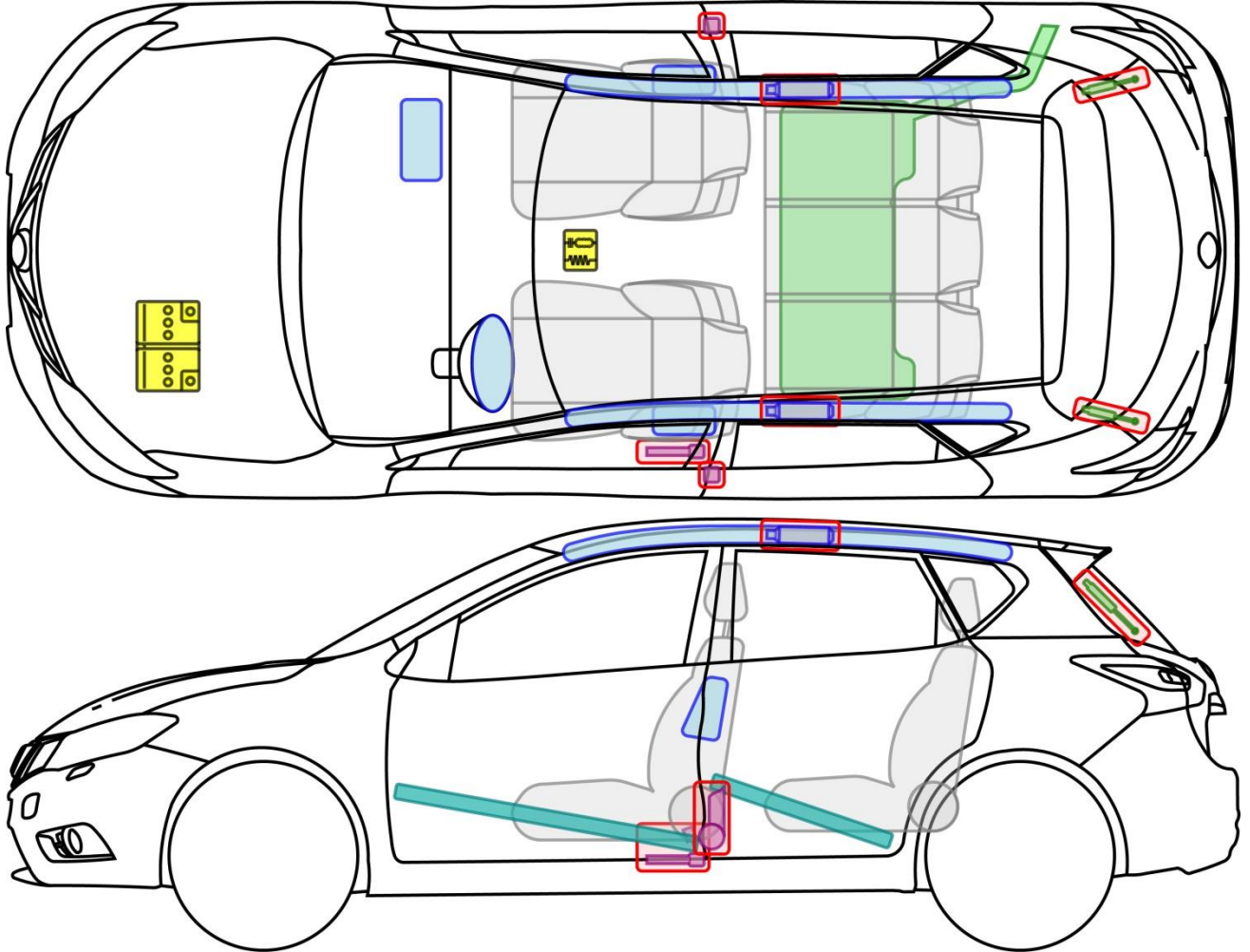

## Legende

	Airbag		Karosserie- verstärkung		Steuergerät
	Gas- generator		Überroll- schutz		Batterie
	Gurt- straffer		Gasdruck- dämpfer		Kraftstoff- tank

PULSAR





# QASHQAI

Typ: J10, 2007-2014

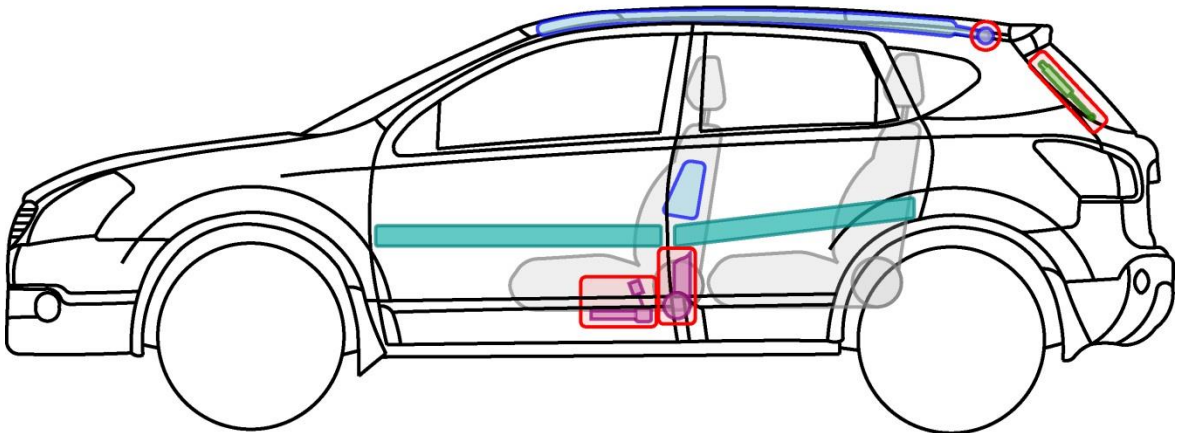
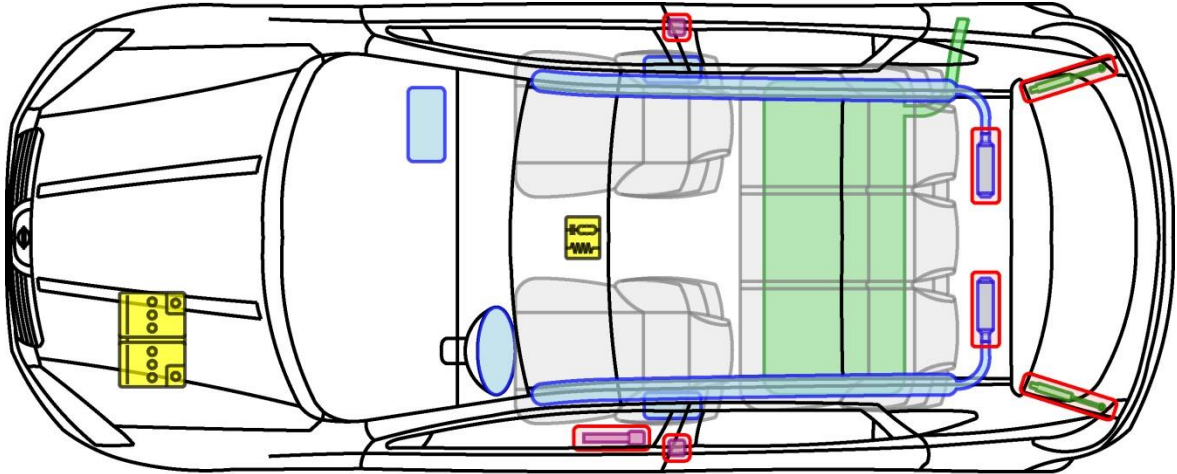

## Legende

	Airbag		Karosserie- verstärkung		Steuergerät
	Gas- generator		Überroll- schutz		Batterie
	Gurt- straffer		Gasdruck- dämpfer		Kraftstoff- tank

**QASHQAI**







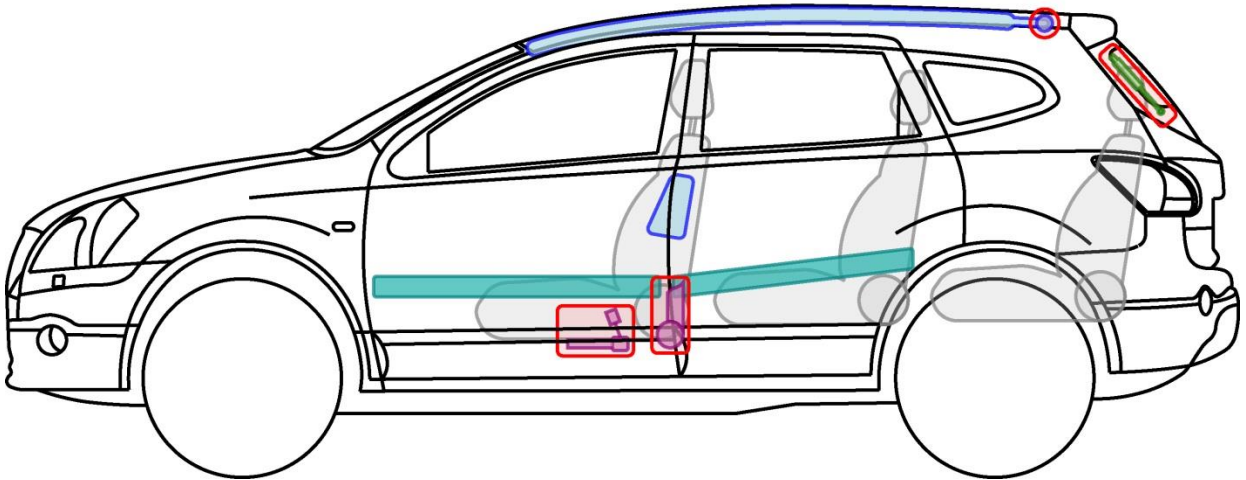
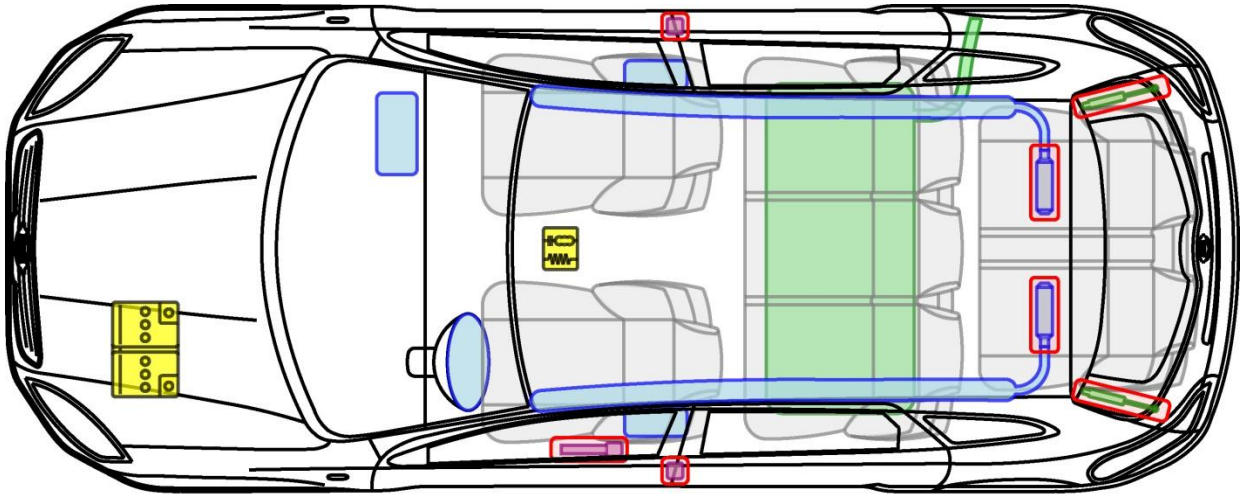

# QASHQAI+2

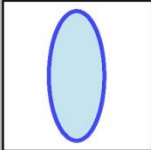
Typ: J10, 2008-2014

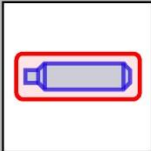

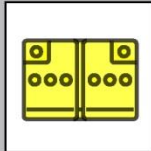
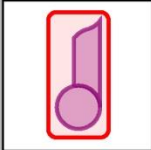
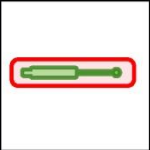
## Legende

	Airbag		Karosserie- verstärkung		Steuergerät
	Gas- generator		Überroll- schutz		Batterie
	Gurt- straffer		Gasdruck- dämpfer		Kraftstoff- tank

QASHQAI+2







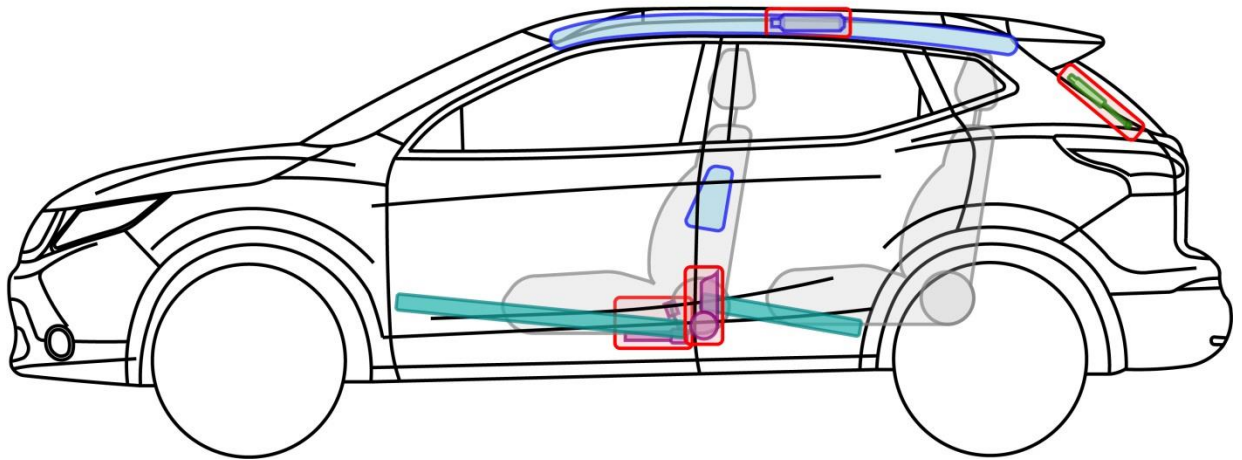
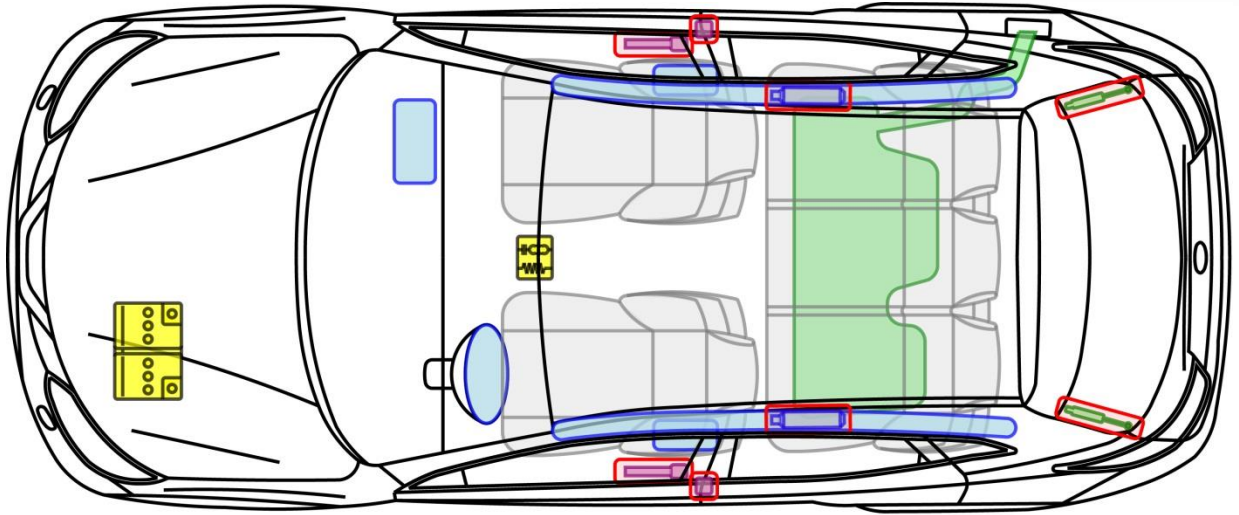

# QASHQAI

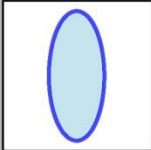
Typ: J11, 2014-

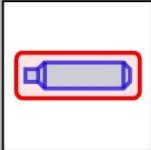

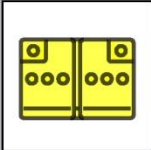
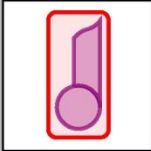
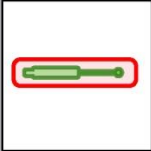
## Legende

	Airbag		Karosserie- verstärkung		Steuergerät
	Gas- generator		Überroll- schutz		Batterie
	Gurt- straffer		Gasdruck- dämpfer		Kraftstoff- tank

**QASHQAI**





# TIIDA

Typ: C11, 2006-2011

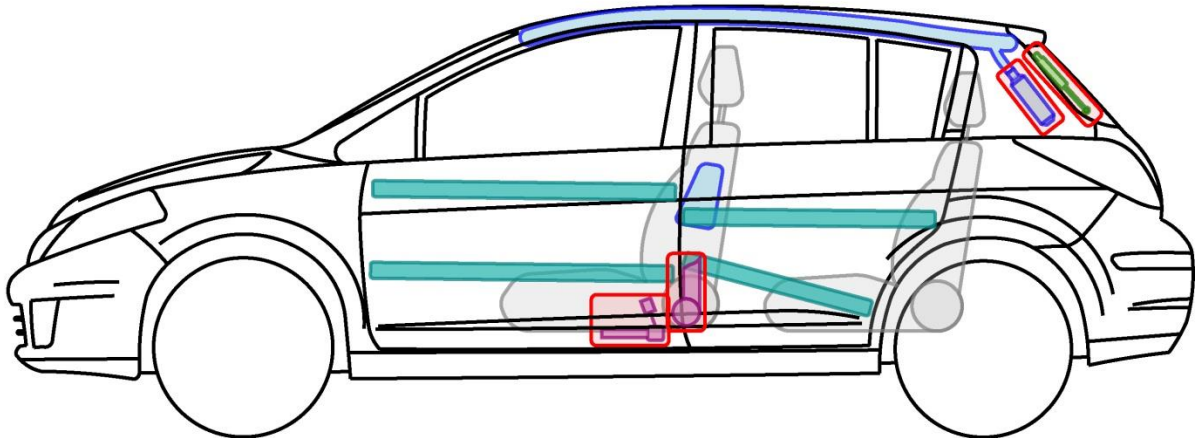
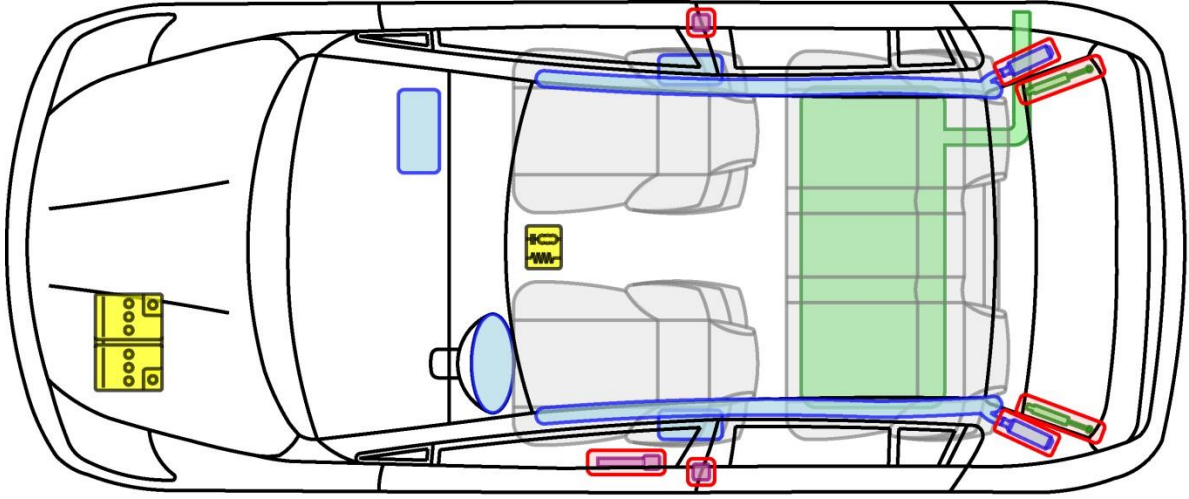

## Legende

	Airbag		Karosserie- verstärkung		Steuergerät
	Gas- generator		Überroll- schutz		Batterie
	Gurt- straffer		Gasdruck- dämpfer		Kraftstoff- tank











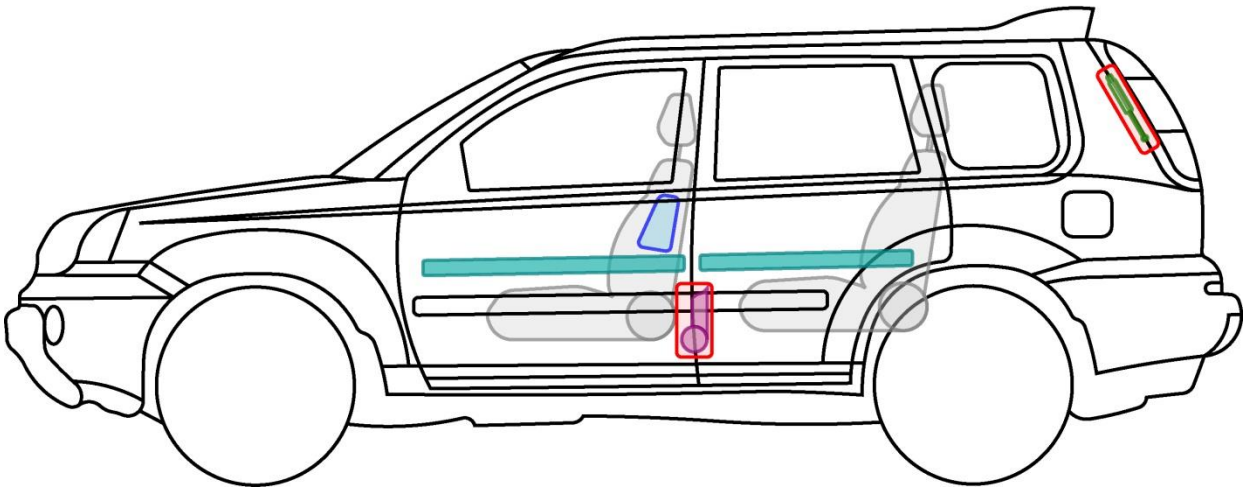
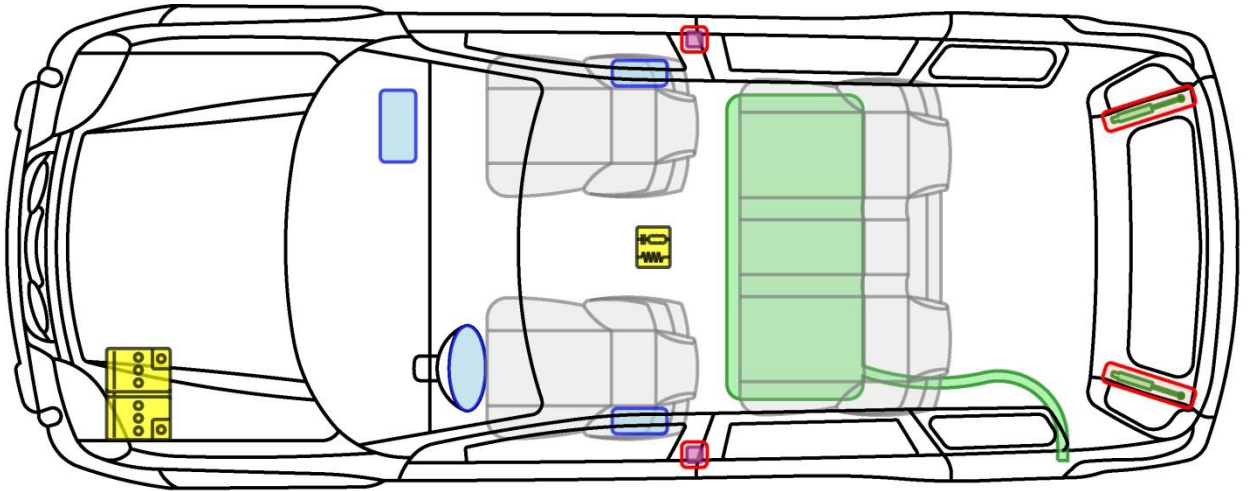

# X-TRAIL

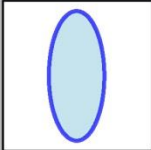
Typ: T30, 2001-2007

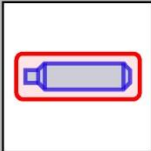

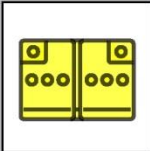
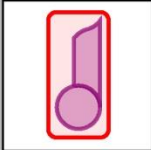
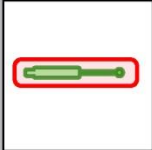
## Legende

	Airbag		Karosserie- verstärkung		Steuergerät
	Gas- generator		Überroll- schutz		Batterie
	Gurt- straffer		Gasdruck- dämpfer		Kraftstoff- tank





# X-TRAIL

Typ: T31, 2007-2014

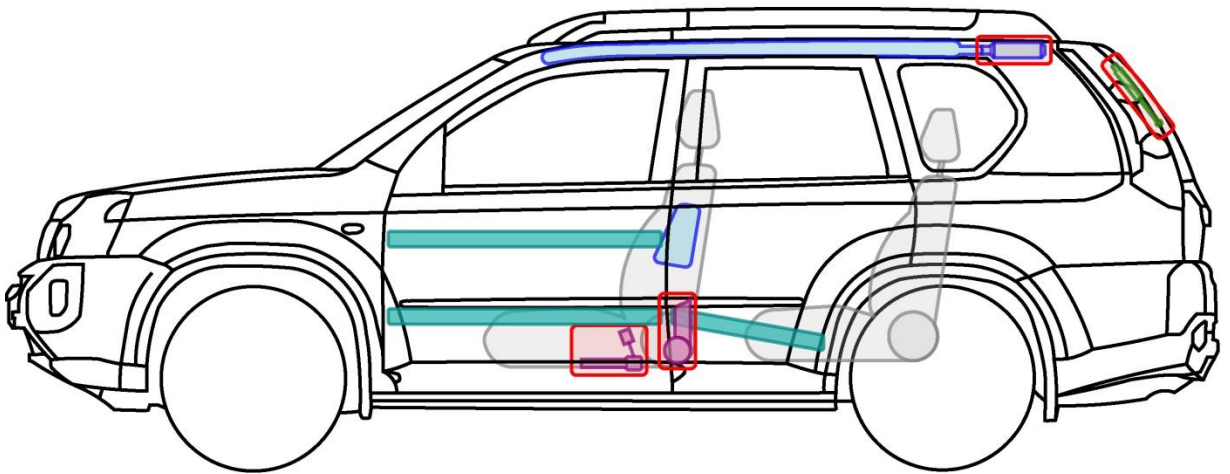
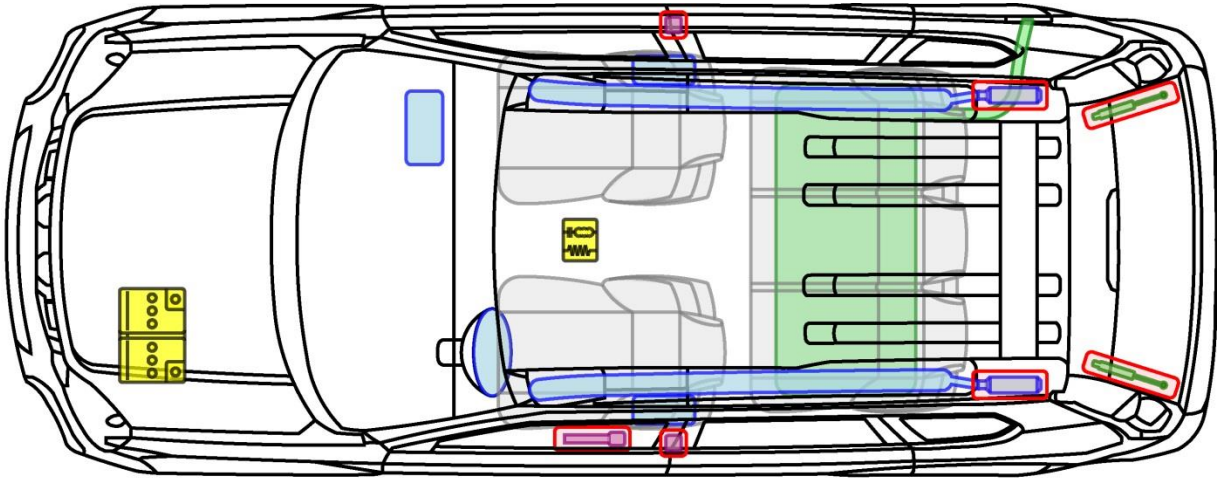

## Legende

	Airbag		Karosserie- verstärkung		Steuergerät
	Gas- generator		Überroll- schutz		Batterie
	Gurt- straffer		Gasdruck- dämpfer		Kraftstoff- tank









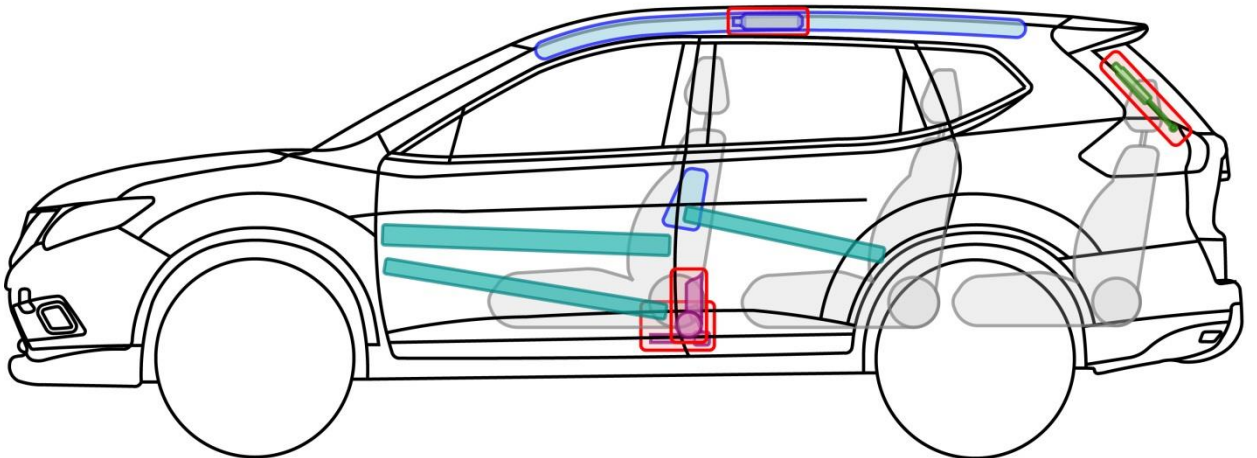
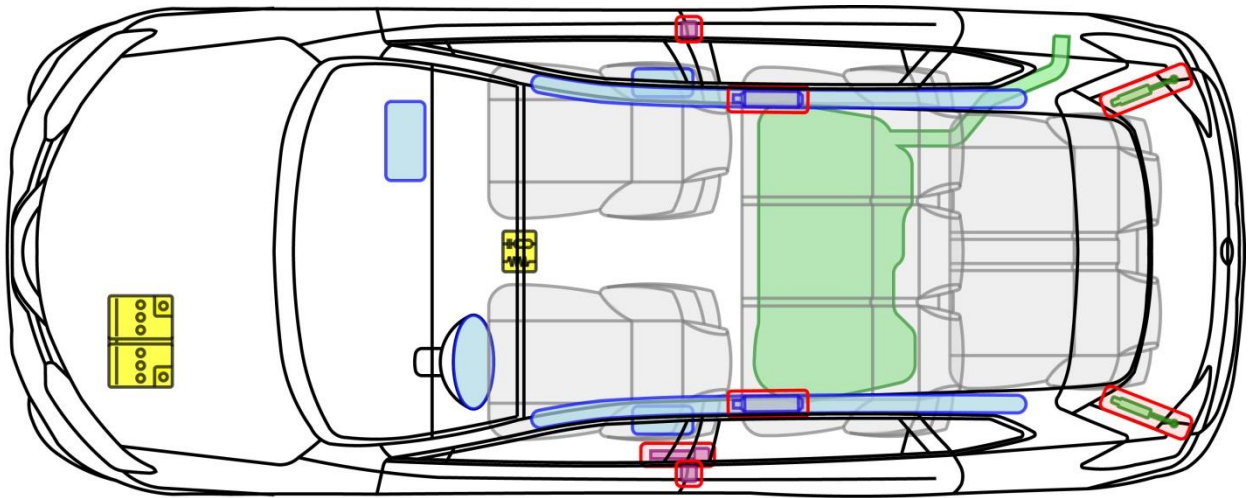

# X-TRAIL

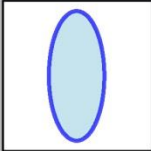
Typ: T32, 2014-

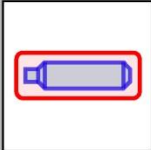

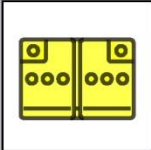
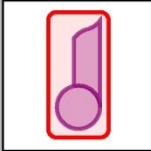
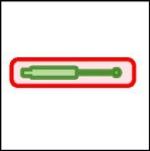
## Legende

	Airbag		Karosserie- verstärkung		Steuergerät
	Gas- generator		Überroll- schutz		Batterie
	Gurt- straffer		Gasdruck- dämpfer		Kraftstoff- tank

**X-TRAIL**